



*Trail to the Past. Road to the Future.*

---

**CITY COUNCIL MEETING**  
MUNICIPAL COUNCIL CHAMBERS  
21 5<sup>TH</sup> STREET E, MANTORVILLE, MN 55955  
MONDAY, March 9, 2026 - 6:30pm

1. **Call to Order**
2. **Pledge of Allegiance**
3. **Changes to Agenda**
4. **Consent Agenda \*\***
  - A. Council meeting minutes 2.9.26
  - B. Commissioners meeting minutes 1.27.26
  - C. County Commissioners Meeting Minutes 2.10.26
  - D. Fire Department March 2026 meeting minutes
  - E. Chamber February 2026 Meeting Minutes
  - F. Accounts Payable (warrant list) for 3.9.26
  - G. Acceptance of Martha Vrieze Park Board resignation 2.25.26
  - H. Mantorville February 2026 Sheriff's Report
  - I. Certification of unpaid fire call invoice Maddox Fritz 121 9<sup>th</sup> St W – Resolution 2026-08  
Authorizing the Certification of Unpaid Charges to the Dodge County Auditor
  - J. Approval of Garbage Hauler license
5. **Proclamations, Presentations and Recognitions**
  - A. Selection of new Councilmember to fill vacant interim seat. \*\*
    1. Jerrod Kappers
    2. Anthony Meyers
    3. Laura Schroeder
    4. Holly Schmidt
    5. William Reding
6. **Public Concerns**

*Individuals may address the City Council about any item not included on the regular agenda. Speakers must come to the podium to be heard, and must state their name and address for the Clerk's record, and remain under the five-minute allotted time limit. Generally, the City Council will not take official action on items discussed at this time but may, typically, refer the matter to Staff for a future report or direct that the matter be scheduled on an upcoming agenda.*
7. **Public Safety Update**
8. **Public Hearings**

- A.** Notice is hereby given that the Mantorville City Council will hold a public hearing on Monday, March 9, 2026 starting at 6:30 p.m., or as soon as reasonably practical thereafter, in the City Council Chambers located at 21 5th Street East, Mantorville, Minnesota, to consider an ordinance amending Mantorville City Code, section 150.073. The proposed ordinance, if adopted, would amend the city's zoning ordinance related to the city's Historic District by replacing all references to the Mantorville Restoration Association (MRA) with references to a separate municipal heritage preservation commission. If adopted, the ordinance will (i) sever the existing relationship between the city and MRA related to property in the Historic District; and (ii) provide that, should the city decide to establish in the future a historic preservation commission under Minn. Stat. 471.193, said commission will assume the responsibilities that are presently delegated to MRA. All interested persons may attend the hearing and provide comments. A copy of the proposed ordinance can be requested or reviewed during business hours at City Hall, 21 5th Street East, Mantorville, MN. If you are unable to attend the meeting, written comments may also be submitted to the City Council prior to the public hearing via email (gretchen@mantorville.com) or dropped off or mailed to City Hall, 21 5th Street East, Mantorville, MN 55955. All written comments submitted prior to the public hearing will be presented to the City Council. Following the public hearing, the City Council will consider and possibly adopt the proposed ordinance. \*\*

Ordinance No. 2026-01 Amending Section 150.073 of the Code of Ordinances of the City of Mantorville Regarding the Historic District

Resolution No. 2026-07 Authorizing Publication of Ordinance No. 2026-01 by Title and Summary

- B.** Notice is hereby given that the Mantorville City Council will hold a public hearing on Monday, March 9, 2026 starting at 6:30 p.m., or as soon as reasonably practical thereafter, in the City Council Chambers, located at 21 5th Street East, Mantorville, Minnesota, related to proposed amendments to the City's master fee schedule. Interested persons may attend the hearing and provide comments. Materials and information regarding the proposed fee schedule revisions, including the proposed ordinance, can be requested from City staff or reviewed during business hours at City Hall, 21 5th Street East, Mantorville, MN. Following the public hearing, the City Council will consider adopting the fee schedule amendments via ordinance. \*\*

Ordinance No. 2026-02 Updating the City of Mantorville's Master Fee Schedule

## **9. New Business**

- A.** Layne Noser with the Mantorville Art Guild update on the Sunday Concert series  
**B.** Balcome Lot Split at 620 6<sup>th</sup> Street West \*\*

Resolution 2026-10 Approving a Lot Split for Certain Real Property Located in Mantorville, Dodge County, Minnesota

- C.** Adjustment of Balcome water bill at 620 6<sup>th</sup> Street West \*\*  
**D.** CMS Contract Monthly Billing for Software with 60 days notice if Council chooses to opt out \*\*  
**E.** Permission for Chamber to use Riverside Park on Saturday April 4<sup>th</sup> for the Easter Egg Hunt \*\*  
**F.** Permission for the Chamber to store items in the City Hall Basement \*\*  
**G.** Approval of Food truck policies and application \*\*



*Trail to the Past. Road to the Future.*

**10. Old Business**

- A. Discussion of property at 101 5<sup>th</sup> Street East – warrant progress

**11. Tabled Items**

- A. Streetlight on HWY 57 across from Casey’s

**12. Reports**

- A. Public Works Report – street sweeping quotes
- B. City Clerk Report – LBAE Meeting is April 20th
- C. Consultant Report – Lead Service Line Funding & Well #3 Feasibility Study

Resolution 2026-09 Approving the City’s Application for a Loan and/or Grant from the Drinking Water Revolving Fund for Lead Service Line Replacement \*\*

- D. Committee Reports  
*Chamber, EDA, Finance/Budget, Fire Department, Infrastructure, KM Joint Powers, MRA, Park Board, Personnel, FD Relief, Township*
- E. Councilmember Reports
- F. Mayor’s Report

**13. Executive Session – No Items**

**14. Adjourn \*\***

<i>Upcoming Meetings and Events in Mantorville:</i>		
<i>March 4, 2026</i>	<i>7:30pm</i>	<i>Fire Dept General Meeting</i>
<i>March 9, 2026</i>	<i>6:30pm</i>	<i>City Council Regular Meeting</i>
<i>March 16, 2026</i>	<i>6:30pm</i>	<i>EDA Meeting</i>
<i>March 31, 2026</i>	<i>6:30pm</i>	<i>1<sup>st</sup> Park and Board Meeting of 2026</i>
<i>Because Mantorville is a small, but active community, a possible quorum may result as members of the City Council and other Boards may be in attendance meeting and community events in Mantorville.</i>		

\*\* Council Action Item





## Draft

### 1. Call to Order

Mayor Ingalls called the meeting to order at 6:30 p.m.

Present: Mayor Jeff Ingalls

Councilmembers:

Lynnette Nash

Kim Boyum

Jim Potter arrived at 7:15pm

Others Present: City Clerk-Treasurer Gretchen Lohrbach  
Public Works Lead Joe Adams  
Public Works Wade Schroeder  
Fire Chief Paul Lushinsky

### 2. Pledge of Allegiance

Everyone stood and recited the Pledge of Allegiance.

### 3. Changes to the Agenda

No changes

### 4. Consent Agenda

- A. Accounts Payable (Warrant List) for 2.9.26
- B. County Commissioners Meeting Minutes 1.13.26
- C. Council Meeting Minutes 1.26.26
- D. Chamber January Meeting Minutes
- E. EDA Meeting Minutes 10.20.25
- F. Fire Department February Meeting Minutes

**G. Park Board Minutes 10.28.25**

Councilmember Boyum moved and Councilmember Nash seconded to approve the consent agenda as presented.

Motion carried: 3 ayes / 0 nays

**5. Proclamations, Presentations and Recognitions**

No Items

**6. Public Concerns**

- A. William Reding would like to apply for the vacant interim Council seat. City Clerk Lohrbach will send him an application.
- B. Cathy Jones had a broken pipe and her water bill is very high as a result.

Councilmember Nash moved and Councilmember Boyum seconded to forgive the excess sewer portion of the bill.

Motion carried: 3 ayes / 0 nays

**7. Public Safety Update**

- A. Fire chief Paul Lushinsky gave an update on the search for a new grass rig. They Have located a chassis & flatbed they can purchase this week. L & L Street Rods can set this up and everything should be under \$170,000. Otherwise, there is another option in California, but it would be around \$25,000 to get it to Minnesota, and we may not have it until June.

Councilmember Nash moved and Councilmember Boyum seconded to go with the L & L option.

Motion carried: 3 ayes / 0 nays

- B. Councilmember Boyum moved and Councilmember Nash seconded approving the fire contracts at the same amounts as last year.

Motion Carried: 3 ayes / 0 nays

## **8. Public Hearings**

No items.

## **9. New Business**

- A. The City Council currently has a non-profit that is not recognized by the state listed in our ordinance for advising the Council on our Historic District. There will be a public hearing on March 9<sup>th</sup> to remove the Mantorville Restoration Association from our ordinance and allow the Council to consult with a Historic Preservation Commission of their choosing.
- B. Duke Harbaugh from Mantorville was present to discuss the Orderly Annexation Agreement they have with the City of Mantorville. It currently involves the northern border of the city. At one time it was East to West. The City must decide how they are going to grow. There is aging infrastructure in certain areas. Mayor Ingalls asked City Clerk Lohrbach to have the City Attorney look into how we could change our annexation agreement since it hasn't been updated since 2010. It would require a public hearing.

## **10. Old Business**

- A. Councilmember Nash moved and Councilmember Boyum seconded to approve the addition of stop signs at the intersection of 8<sup>th</sup> Street East and Blanch Street on the Northern and Southern sides of the road.

Motion carried: 3 ayes / 0 nays

- B. The City Attorney is working on a warrant to grant access to the City's Building Inspector for the property located at 101 5<sup>th</sup> Street East.
- C. There will be a Public Hearing on March 9<sup>th</sup> to change the Master Fee Schedule for the year 2026.

## **11. Tabled Items**

- A. Streetlight on HWY 57 across from Casey's was not pulled from the table.

## **12. Reports**

### **A. Public Works Report**

- 1) Friday they will be working on the valve and water meter at City Hall. The water will need to be shut off for Mantor Drive and Bergmann Drive and part of East 6<sup>th</sup> Street for the repairs. Water will be off Friday September 13<sup>th</sup> from 8:00am – 1:00pm.

## **B. City Clerk Report**

- 1) Deputy City Clerk Wendy Siewert is working on a food truck policy for the City and correction on the City's Personnel Policy.
- 2) City Clerk Lohrbach asked if the Deputy City Clerk's and City Clerk's wage raises will be retroactive through January. Council said yes.

## **C. Consultant Report**

No Items.

## **D. Committee Reports**

- 1) Chamber
  - The annual dinner has been scheduled for Thursday and there are still tickets available. Next month are the officer elections.
- 2) Economic Development Authority
- 3) Finance/Budget
- 4) Fire Department
  - Will be attending the monthly Council meetings.
- 5) Infrastructure
- 6) Kasson Mantorville Joint Powers
  - Matt Wohlenhaus from the City Park Board presented updates about the new Riverside Park Hockey Rink.
  - The next meeting is April 9<sup>th</sup>.
- 7) Mantorville Restoration Association
- 8) Park Board
  - Meets in March on the last Monday at 6:30pm.
- 9) Fire Relief

10) Personnel

11) Relief

12) Township

- Elections will be in March and they are setting the levy for year 2027. They are comfortable leaving the Fire Contract as it is for now.

#### **E. Councilmember Reports**

- Kim Boyum reported that the Hayfield Schools Art Show is the 12<sup>th</sup> through the 19<sup>th</sup>. Also, the MRA's Mulligan Stew Fundraiser is March 12<sup>th</sup> at 4:30-7:30pm. "Sipping With Seniors" is also going on the last Friday of every month from 2:00 – 4:00pm at Prairie Meadows in Kasson.

#### **F. Mayor's Report**

- Mayor Ingalls met with the Kasson-Mantorville Schools new Superintendent.
- The 40 acres annexed into Mantorville near the school has a company interested in buying it that wants to put in solar panels. The school may be interested in purchasing the acreage if a developer is not.

### **13. Adjourn**

Motion was made by Councilmember Boyum and seconded by Councilmember Potter to adjourn the meeting at 7:20pm.

Motion carried: 4 ayes / 0 nays. Meeting adjourned.

---

Gretchen Lohrbach  
City Clerk-Treasurer

**UNAPPROVED MINUTES OF THE  
DODGE COUNTY BOARD OF COMMISSIONERS REGULAR MEETING HELD  
JANUARY 27, 2026**

**Chair**

**Convene County Board Meeting**

The Dodge County Commissioners met in regular session January 27, 2026, in the County Board Room at the Dodge County Government Services Building, Mantorville, MN, at 5:00 p.m. Chair David Kenworthy called the meeting to order at 5:00 p.m.

<b>Attendee Name</b>	<b>Title</b>	<b>Status</b>	<b>Arrived</b>
John Allen	District 1	Present	5:00 PM
Tim Tjosaas	District 2	Present	5:00 PM
Rodney Peterson	District 3	Present	5:00 PM
Rhonda Toquam	District 4	Present	5:00 PM
David Kenworthy	District 5	Present	5:00 PM

**Pledge of Allegiance**

The pledge of allegiance was recited.

**Determine Quorum**

The Chair acknowledged those present and established there was a quorum.

Also present:

Jim Elmquist            County Administrator  
Becky Lubahn            Deputy Clerk  
Paul Kiltinen            County Attorney

**Establish Agenda**

**Agenda Approved**

Motion by Tjosaas seconded by Peterson to approve and adopt the agenda as presented.

*Motion Adopted [Unanimous]*

**Consent Agenda**

Motion by Peterson seconded by Toquam to approve the following Consent Agenda items:

*Motion Adopted [Unanimous]*

- 1.1. Committee of the Whole - Committee Meeting - Jan 13, 2026 9:10 AM
- 1.2. Board of Commissioners - Regular Meeting - Jan 13, 2026 9:30 AM

- 1.3. Purchase of Tandem Plow Trucks
- 1.4. Purchase of SnoGo Snowblower

**Jim Finn, Big Iron Classic Representative****Revisit Big Iron Classic's Use of The Midway**

Big Iron Classic Truck Show board members Jim Finn, Pat Barker and George Arndt were present to discuss the Big Iron Classic's use of The Midway for the truck show.

The purpose of this meeting will be to discuss the rental of The Midway building at the Dodge County Fairgrounds on September 11-12, 2026 during their event.

The promoters stated the nonprofit truck show attracts thousands of spectators and participants each year and provides a significant boost to local businesses.

Mr. Finn informed the Board that there are mixed feelings regarding the use of The Midway building at the fairgrounds. He noted that its construction resulted in the loss of land previously used for truck parking during the truck show. Initially, they had access to the entire fairgrounds and all buildings, but additions and new construction have reduced the space available for the truck show.

Mr. Arndt stated that he believed he read online that the fee for use of the building would be waived for charitable organizations.

This assumption was incorrect, as no such option was ever approved by the County Board or included in any agreements, use permits or website information related to The Midway.

Commissioner Peterson expressed appreciation for the group's work and recognized that the event brings numerous trucks, people, and vendors into the area. However, he stated that the county does not directly benefit since the event is held in Kasson and benefits the City of Kasson. He also noted that information suggesting the building could be used free of charge by nonprofits is incorrect.

Mr. Finn stated that the City of Kasson is not the only entity that has benefited from the truck show, noting that the Fair Board has also benefited, and therefore he believes Dodge County has benefited as well.

Commissioner Peterson clarified that the Fair Board is a separate entity from the county. Mr. Peterson noted that the county waived the fee for use of the Midway last year and acknowledged that some truck parking space was lost when The Midway was constructed.

It was reported that they estimate approximately 50 truck parking spaces were lost in the area now occupied by The Midway.

Mr. Barker noted that they also lost parking spots due to the horse barn expansion and the construction of the new water tower.

Representatives of the Big Iron Classic requested that the County waive The Midway usage fee for the Big Iron Classic Truck Show, noting that they have lost a significant number of parking spaces for the truck show.

A question was raised regarding how The Midway is used during the truck show.

Mr. Finn reported that the building is used to sell show t-shirts and host vendor displays. He added that they are trying to keep prices down and make the show affordable for everyone.

Commissioner Allen noted that vendor space in the building is rented out during the truck show, so they are receiving money from the vendors for the rented indoor space.

Jim Finn reported that they only rent out five vendor spaces in The Midway.

Pat Barker informed the Board that they place t-shirts in the building to help draw people into the building.

Facilities & Fleet Manager Duke Harbaugh was present and informed the Board that the Big Iron Classic Truck Show promoters have been good to work with. He noted that they lock the building's doors before the evening crowd becomes rowdy, and there have never been any issues with their use of the facility.

Commissioner Kenworthy stated that they are a 501(c)(3) nonprofit and support many outside organizations through donations.

Commissioner Peterson informed the truck show representatives that the county is proud of The Midway building and has invested significant funds in the building and fairgrounds upgrades. He noted that these improvements have been costly for the county, and the rental fee was intended to help recoup some of those expenses. Mr. Peterson reported that after speaking with the three representatives, he has been convinced not to charge the Big Iron Classic a rental fee for the truck show's use of The Midway.

Motion by Peterson seconded by Tjosaas to approve and authorize the Big Iron Classic Truck Show to use The Midway building at no cost annually.

No vote was taken.

Commissioner Kenworthy informed the representatives that a contract is still needed for the use of the building, even if they aren't being charged a fee. Mr. Kenworthy reported the Fair Board and Dodge County are separate entities and we have our own rental agreements that need to be completed. Mr. Kenworthy asked that this information be included in the motion. Everyone was in agreement to amend the motion to include this language.

Motion by Peterson seconded by Tjosaas to approve and authorize the Big Iron Classic Truck Show's use of the Midway building annually at no charge, contingent upon execution of the

rental agreement and use permit to reserve the building for the truck show.

Mr. Barker suggested that they work with the Facilities & Fleet Manager each year to ensure the grounds are inspected and returned to pre-use conditions.

Commissioner Toquam asked where the toys collected during the show are distributed and whether they can be directed back to Dodge County residents.

Pat Barker reported that he has worked with Vince Reynolds, who is the Toys for Tots Coordinator for Southeast Minnesota. The toys collected through this program stay within Southeast Minnesota. Mr. Barker stated he could approach Mr. Reynolds to request that more focus be placed on donating toys specifically within Dodge County.

Commissioner Kenworthy added that he knows Mr. Reynolds is very focused on ensuring Dodge County needs are met first, before distributing donations elsewhere.

Commissioner Tjosaas wants to know what can be done to keep the golf carts off the sidewalks and out of the areas where they are restricted. He lives near the fairgrounds and has observed an increase in golf carts operating in unauthorized areas during the truck show. He suggested that the promoters come up with a plan to ensure that golf carts are kept off sidewalks and restricted zones through better enforcement and controls.

Mr. Barker reviewed the golf cart registration procedures for the event and discussed the strategies being used to reduce issues related to golf cart usage during the event.

*Motion Adopted [Unanimous]*

### **Duke Harbaugh, Facilities & Fleet Manager & Becky Lubahn, Executive Assistant 2025 Midway Usage Review**

Mr. Harbaugh reported that in the calendar year 2025 there were 29 events at the Midway with only 3 paid rentals. So far in 2026 the first wedding has been booked, and we have already hosted a private event last week as we anticipate the rentals will grow as the building gets more public attention. Included in the board packet was a chart that illustrates the space usage broken down by department/agency. The grey represents the small amount of reservations Dodge County received payment for use of the building.

Over the calendar year 2025 Dodge County spent about \$16,724 in operational costs i.e., gas, water, electric to operate the facility along with roughly 115 labor hours setting up/tearing down and cleaning the facility after each use adding roughly \$3,744 in additional labor cost bringing the rough total to operate the facility to \$20,468 for 2025.

With a rough operation cost of \$20,468 for calendar year 2025 divided by the 29 reservations we would have had to charge \$705 for each reservation to break even on the cost of operation.

With this in mind, going forward the Facilities & Fleet Manager feels we need to start charging a reduced rate for the use of the building for all reservations to cover some of the costs it takes to operate. This idea was brought forward last year and they ultimately decided to wait and see how the first year went so they could come back with some data. Mr. Harbaugh pointed out that this does not include other staff time for reservations, website, calendars and other administrative work as it just includes the consumables and labor for the facility.

The Facilities & Fleet Manager informed the Board that he also would like to cover the tables and chairs and who is responsible for their rental, return, storage, etc. The county had two new tables go missing after the Fair and the Fair Board gave the county two (not the missing two). Maintenance staff has labeled all the county owned tables and chairs with clear identifiers but without locking them up, Mr. Harbaugh believes we will continue to lose tables and chairs, especially during the fair. Mr. Harbaugh wanted to know what the Board's thoughts were on the tables and chairs as the Fair Board owns enough to supplement what is needed to fully set up the Midway, so we have to work together to agree on something. Currently it was the thought the Fair Board would rent out the tables and chairs and retain the funds generated from rentals, but no one can afford to be losing tables and chairs. The County could look at purchasing a steel storage container and securing everything while keeping a tighter inventory than what the Fair Board is currently doing. This would allow staff to ensure what goes out comes back in after every event. The Facilities & Fleet Manager state he is looking for some direction as to what the County Board desires moving forward.

Mr. Harbaugh noted that they limit The Midway usage to groups of fewer than 50 participants in an effort to keep expenses down. The Facilities & Fleet Manager feels groups under 50 are better suited for the Board Room considering the cost of operating The Midway.

Commissioner Allen stated that he likes the idea of using the Board Room instead of The Midway for groups under 50.

Commissioner Kenworthy felt that Mr. Harbaugh provided the Board with a solid cost analysis. He noted that the current numbers don't look favorable without a significant number of rentals, but as building use increases, he believes the costs to operate the building will be offset.

Commissioner Tjosaas stated that he would have difficulty charging other departments to use the building, as it would simply be an internal transfer of funds. He appreciated the analysis and noted that the county incurs a cost each time the building is opened for use.

Commissioner Toquam wanted to know what the offset would be if they took out the cost of the confirmed rentals for this year.

The Facilities & Fleet Manager reported that it would be about \$4,000 less, which calculates to roughly \$16,468 for the year.

Mr. Harbaugh further discussed concerns about table and chair security and questioned whether the county needs dedicated storage. He also discussed purchasing enough tables and chairs to outfit the facility later this year. The Facilities & Fleet Manager said he is reluctant to order more without secure storage, as new tables were lost during the first year of use. Mr. Harbaugh proposed purchasing a storage container at The Midway for secure storage of the county's chairs and tables.

The Board discussed with Mr. Harbaugh who has keys to access The Midway.

Commissioner Allen reported that he is not in favor of the Fair Board having keys the building and access to the chairs and tables.

Commissioner Toquam suggested that they consider installing keypad lock system.

The Facilities & Fleet Manager reported that he did look into installing a keypad at The Midway, but it would cost \$5,000.

Commissioner Allen stated he was in favor of Mr. Harbaugh and Ms. Lubahn being the keeper of the keys for the facility.

The Facilities & Fleet Manager proposed the future installation of a storage container next to The Midway to securely store tables and chairs and prevent them from being used elsewhere on the grounds.

Key options for the building were further discussed. Mr. Harbaugh informed the Board that he has already re-keyed the building once because there were too many keys out there, and they weren't sure who had keys or access to the building.

Commissioner Kenworthy questioned whether a storage container should be provided to store the chairs and tables.

Commissioner Allen reported that he would like to see a one-key system in place, with only two county staff members as key holders, and stated he was not opposed to a conex box to store tables and chairs.

Commissioner Kenworthy stated that the building has an attractive appearance and expressed concern that a storage container could detract from its look.

Commissioner Tjosaas stated he was comfortable with re-keying the building and installing a conex box if that approach doesn't work.

On another note, Mr. Harbaugh informed the Board that the City of Kasson would like to install solar at the fairgrounds. The City of Kasson has applied for a grant to put solar panels on the ice arena at no cost to the county.

Commissioner Tjosaas asked where the power generated by the panels goes and if it feeds back into the building.

The Facilities & Fleet Manager reported the power generated by solar panels on the Ice Arena would go back into the grid.

Commissioner Kenworthy informed the Board that this topic was discussed at an Ice Area meeting and that he advised those present he was not in favor of installing solar panels on the ice arena. He stated that he has never agreed to support the request or approved it as a county representative at an Ice Arena meeting.

Commissioner Allen stated that he felt more information was needed regarding the request.

Commissioner Tjosaas reported that he spoke with the Mayor of Kasson regarding the solar grant and was told it would be free for government entities. He noted that the buildings to be included were not specified and that during his conversation with the Mayor he did not equate the grant the Mayor was referring to would include the county building. He stated he saw no cost savings to the county from installing solar panels on the ice arena.

Commissioner Kenworthy expressed concern with placing holes in a roof that was not designed for such penetrations and stated that installing solar panels on the Ice Arena could lead to future problems.

Commissioner Toquam was not supportive of putting solar panels on the Ice Arena.

The consensus is the Board was that they do not support installing solar panels on the Ice Arena.

*Motion No Vote*

**Duke Harbaugh, Facilities & Fleet Manager**  
**Elevator Service Agreement**

Mr. Harbaugh informed the Board that in late 2025 he was able to submit the county's intent to terminate our Service Contract with TKE to explore competitive options servicing Dodge County's four passenger elevators within the Courthouse and Government Service Building. He reached out to vendors to tour the facilities and see the cab and equipment rooms at both locations and has included all three proposals in the board packet for the Board's review. The Facilities & Fleet Manager had the Attorney's Office review the contract with MEI and it is his recommendation Dodge County move forward with contracting the elevator service with MEI beginning February 1, 2026 and allow him to sign the contract as presented.

Motion by Allen seconded by Tjosaas to approve and authorize the Facilities & Fleet Manager to sign a Preventative Maintenance Agreement with MEI Total Elevator Solutions at a cost of approximately \$3,696.00 per year for elevator service beginning February 1, 2026.

*Motion Adopted [Unanimous]*

### **Nichole Farnsworth, Employee Relations Director**

#### **Personnel Agenda**

Ms. Farnsworth presented the Personnel Agenda for the Board's consideration.

Motion by Allen seconded by Toquam to approve the following personnel actions:

#### **A. Sheriff's Office**

A.1 Myles Wolters - Deputy

Authorization to hire at C41 step 3 \$36.60 to fill approved vacancy.

Effective Date: 1/20/26

A.2 Adam Meier - 911 Dispatch

Authorization to hire at B23 step 1 \$25.45 to fill approved vacancy.

Effective Date: 1/26/26

A.3 Part-time Sheriff's Office staff review of FTE status. The following changes need to be made according to average hours worked. The next audit will be 7/2026.

Bob Morris - Deputy Sheriff

Increase FTE from .50 to .55 FTE.

Effective Date: 1/1/26

#### **B. Attorney's Office**

B.1 Assistant County Attorney - 1.0 FTE

Authorization to post and fill vacancy.

Effective Date: 1/27/26

#### **C. Administration**

C.1 Nolan Zippel - Information Systems Specialist

No longer employed.

Effective Date: 1/20/26

C.2 Information Systems Specialist - 1.0 FTE

Authorization to post and fill vacancy.

Effective Date: 1/27/26

C.3 Part-time Administration staff review of FTE status. The following changes need to be made according to average hours worked. The next audit will be 7/2026.

Becky Lubahn - Executive Assistant  
Decrease FTE from .95 to .90 FTE.  
Effective Date: 1/1/26

**D. Finance**

D.1 Part-time Finance staff review of FTE status. The following changes need to be made according to average hours worked. The next audit will be 7/2026.

Sarah Johnson - Accounting Services Lead

Increase FTE from .95 to 1.0 FTE.

Effective Date: 1/1/26

**E. Public Health**

E.1 Jennifer Therring - Public Health Nurse II

Step increase from C41 step 3 \$45.95 to C41 step 2 \$47.35.

Effective Date: 1/12/26

E2. Kathy Struckmann - Public Health Lead

Status change from Public Health Nurse II to C41 step 3 \$45.95 to Public Health

Lead C43 step 5 \$47.36.

Effective Date: 2/2/26

*Motion Adopted [Unanimous]*

**Kevin Venenga, Finance Director**

**Bills Reviewed**

Mr. Venenga reviewed bills with the Board.

Motion by Toquam seconded by Peterson to approve the bills as discussed in the following amounts from the appropriate funds as determined by Finance:

01 Revenue Fund	\$ 137,666.00
13 Road and Bridge Fund	\$ 946,307.91
16 Environmental Quality Fund	\$ 8,164.27
37 Debt Fund-County Go	<u>\$ 949,531.75</u>
Total	\$2,041,669.93

*Motion Adopted [Unanimous]*

**Paul Kiltinen, County Attorney**

**Legal Update**

Mr. Kiltinen provided the Board with a legal update.

*Motion No Vote*

**Public Health Committee Report - Commissioner Rhonda Toquam**

Commissioner Toquam presented a summary of the Public Health Committee report and action items.

### Request for Out of State Travel

Public Health is requesting authorization for Madison Snitker to attend the 2026 Government Social Media Conference (GSMCON). Public Health continues to find ways to build trust following the COVID pandemic. This conference will support training for public sector communicators educating on best practices and strategies for the county's health department to communicate effectively while building trust. Ms. Snitker developed Public Health's communication plan and risk communication plan over the past year per MDH requirements. The next phase is for her to attend additional training to best implement strategies within that communications plan. She is the department's primary social media communications staff member.

The estimated costs to attend the 2026 GSMCON is \$2,300 for hotel, registration, travel, and meals. This is a budget expense within the CDC Infrastructure Grant, intended for staff development.

Motion by Toquam seconded by Tjosaas to approve and authorize Madison Snitker to attend the 2026 Government Social Media Conference in New Orleans, LA May 5-7, 2026 at a cost of approximately \$2,300 for hotel, registration, travel and meals as requested.

*Motion Adopted [Unanimous]*

### Request to Approve Public Health Donations

This is a request to accept crochet infant character hats from Dodge Center Dorcas Society, Dodge Center, MN.

Commissioner Toquam offered the following resolution (#2026-04), seconded by Commissioner Peterson:

**WHEREAS**, the Dodge County Public Health Department has received donations from Dodge Center Dorcas Society; and

**WHEREAS**, the Dodge County Public Health Department wishes to accept this donation and utilize it for the purpose of distributing to family home visiting clients; and

**WHEREAS**, pursuant to Minnesota Statute 465.03, the county shall by resolution of the governing body adopted by a two-thirds majority of its members accept a grant or devise of real or personal property and maintain such property for the benefit of its citizens in accordance with the terms prescribed by the donor.

**NOW THEREFORE BE IT RESOLVED**, that the Dodge County Board of Commissioners hereby accepts the following donation to be used for the Public Health Programs:

Dodge Center Dorcas Society, Dodge Center, MN	\$120.00
Crochet character hats (6)	

*Resolution Adopted [Unanimous]*

**Administration Committee Report - Commissioner David Kenworthy**

Commissioner Kenworthy presented a summary of the Administration Committee report and action items.

Commissioners provided their agency reports. Commissioner Allen attended a Dodge County Historical Society meeting and a Soil & Water meeting. Commissioner Kenworthy attended a MNSEB Steering Committee meeting, a Safety Committee meeting, a Rochester Airport Zoning meeting and a Fairview Care Center meeting. Commissioner Peterson attended Mental Health Sub-Committee meetings, a SEMMCHRA meeting on hiring, a Rochester Airport hearing, a Dodge County Fair Board meeting and a Fairview Care Center meeting. Commissioner Tjosaas attended a MnPrairie meeting, a Spero meeting, a Fairview Care Center meeting and a Public Health meeting. Commissioner Toquam attended a Spero meeting, a Fairview Care Center meeting and a County Board meeting.

Jeff Therring from Vernon Township was present and asked for clarification on possible hunting regulation changes in Dodge County. He wanted to know if the county is going to pursue a shotgun only hunting season.

Commissioner Kenworthy reported they are going to be looking into drafting an ordinance to stay with a shotgun only ordinance during deer hunting season in Dodge County.

It was noted that the county is waiting for a model ordinance example from the Association of Minnesota Counties. Mr. Therring was informed there will be a public meeting held on this topic at a later date.

*Motion No Vote*

There were no Other Deferred Business items to discuss.

*Motion No Vote*

**Adjourn****Meeting Adjourned**

Motion by Peterson seconded by Tjosaas to adjourn the meeting at 6:09 p.m.

The next regular meeting of the Dodge County Board of Commissioners will be held on February 10, 2026 at 9:30 a.m.

*Motion No Vote*

<p><b>UNAPPROVED MINUTES OF THE DODGE COUNTY BOARD OF COMMISSIONERS REGULAR MEETING HELD FEBRUARY 10, 2026</b></p>
--

**Chair**

**Convene County Board Meeting**

The Dodge County Commissioners met in regular session February 10, 2026, in the Board Room at the Dodge County Government Services Building, Mantorville, MN, at 9:30 a.m. Chair David Kenworthy called the meeting to order at 9:30 a.m.

Attendee Name	Title	Status	Arrived
John Allen	District 1	Absent	
Tim Tjosaas	District 2	Present	9:30 AM
Rodney Peterson	District 3	Remote	9:30 AM
Rhonda Toquam	District 4	Present	9:30 AM
David Kenworthy	District 5	Present	9:30 AM

Commissioner Peterson was attending remotely from 22062 650th Street, Kasson, MN.

**Pledge of Allegiance**

The pledge of allegiance was recited.

**Determine Quorum**

The Chair acknowledged those present and established there was a quorum.

Also present:

Jim Elmquist	County Administrator
Becky Lubahn	Deputy Clerk
Paul Kiltinen	County Attorney

**Establish Agenda**

**Agenda Approved**

Motion by Toquam seconded by Tjosaas to approve and adopt the agenda as

*Motion Adopted [Unanimous]*

**Consent Agenda**

Motion by Tjosaas seconded by Toquam to approve the following Consent Agenda items:

*Motion Adopted [Unanimous]*

- 1.1. Committee of the Whole - Committee Meeting - Jan 27, 2026 4:35 PM
- 1.2. Board of Commissioners - Regular Meeting - Jan 27, 2026 5:00 PM
- 1.3. Award 2026 Season Supplies

**Guy Kohlhofer, County Engineer****Appoint Noah Baumgarten as County Engineer**

It was reported that with the planned retirement of Mr. Kohlhofer, the current County Engineer, there is a statutory responsibility of the Board of Commissioners to appoint a qualified professional to lead the engineering and highway operations of the County.

Noah Baumgarten, a registered Professional Engineer (P.E.), was recently hired to fill this role. Noah possesses the necessary experience and qualifications to fulfill the duties of this office, and Mr. Kohlhofer feels it is in the best interest of the County to appoint him to this position.

Motion by Toquam seconded by Tjosaas to appoint Noah Baumgarten as the County Engineer of Dodge County for a term of one year, 2 months.

*Motion Adopted [Unanimous]*

**Nichole Farnsworth, Employee Relations Director****Personnel Actions Reviewed**

Ms. Farnsworth presented the Personnel Agenda for the Board's consideration.

Motion by Tjosaas seconded by Toquam to approve the following personnel actions:

**A. Highway Department**

A.1 John Marx - Operator

Step increase from B23 step 1 \$29.68 to B23 step 2 \$30.42.

Effective Date: 12/1/25

**B. Environmental Services**

B.1 Renae Forsman - Customer Service ReUse Center

Step increase from A11 step 11 \$18.41 to A11 step 10 \$18.68.

Effective Date: 2/25/26

**C. Land Records**

C.1 Alysia Borowski - Land Records Clerk

Step increase from B22 step 10 \$24.50 to B22 step 9 \$25.30.

Effective Date: 2/26/26

**D. Public Health**

D.1 Amy Evans - Public Health Director

Step increase from D71 step 7 \$61.85 to D71 step 6 \$63.70.

Effective Date: 1/31/26

D.2 Brenda Gullickson - Business Office Manager

No longer employed.  
Effective Date: 2/3/26

*Motion Adopted [Unanimous]*

**Lauren Cornelius, Environmental Services Director & Rita Cole, Waste Management Administrator**

**2026 Hauler Licenses**

Ms. Cornelius and Ms. Cole presented for the Board's consideration a request to vote in favor of the proposed resolution to issue 2026 licensure to the following waste haulers: Waste Management of Rochester; Tracy Services; Skjeveland Enterprises; Freeborn County Coop Oil; Northstar Recycling; Veit Disposal; Harters Disposal of MN; Thompson Sanitation; Aspen Waste Systems of MN; and LRS of Minnesota, LLC.

Commissioner Tjosaas offered the following resolution (#2026-05), seconded by Commissioner Peterson:

**WHEREAS**, the following waste haulers have applied for a license to collect and transport solid waste in Dodge County:

Waste Management of Rochester; Tracy Services; Skjeveland Enterprises; Freeborn County Coop Oil; Northstar Recycling; Veit Disposal; Harters Disposal of MN; Thompson Sanitation; Aspen Waste Systems of MN; and LRS of Minnesota, LLC

**WHEREAS**, the Dodge County Environmental Services Department has reviewed the hauler's application and supplemental information and finds that it meets requirements set forth in Dodge County Solid Waste General Ordinance No. 1.

**THEREFORE, BE IT RESOLVED**, that the Dodge County Board of Commissioners grants a license to collect and transport solid waste in Dodge County for a period from February 11, 2026 through February 11, 2027 to the following haulers:

Waste Management of Rochester; Tracy Services; Skjeveland Enterprises; Freeborn County Coop Oil; Northstar Recycling; Veit Disposal; Harters Disposal of MN; Thompson Sanitation; Aspen Waste Systems of MN; and LRS of Minnesota, LLC

**BE IT FURTHER RESOLVED** that the enforceable conditions of each license are as follows:

- The licensee will comply with all provisions of Dodge County Ordinance and state law.
- The licensee will pay Transfer Station Tipping Fee and Waste-to-Energy Service Charge as determined by Dodge County.

*Resolution Adopted [Unanimous]*

**Kevin Venenga, Finance Director**

**Appointment of Authorized Signers**

Mr. Venenga reported that with the change in the Chair of the Board of Commissioners and the recent staff change in the Accounting Services Lead, the list of authorized signers on the accounts of MBT Bank needs to be updated. As a result of MBT policy changes, they are requesting a resolution from the Board of Commissioners authorizing these changes. Included in the board packet was a proposed resolution requesting approval to allow the necessary changes to be made at the bank.

Commissioner Tjosaas offered the following resolution (#2026-06), seconded by Commissioner Toquam:

**WHEREAS**, the Dodge County Board of Commissioners recognize there are certain individuals who are employed with Dodge County and/or members of the Board of Commissioners that are assigned the duty of banking operations; and

**WHEREAS**, the Dodge County Board wishes to establish the authority for the Chairman of the Board of Commissioners, the County Administrator, the Finance Director and the Accounting Services Lead with the authority of handling banking operations; and

**WHEREAS**, the Dodge County Board wishes to establish the authority over the accounts associated with Dodge County as follows: for the Chairman of the Board of Commissioners, authority over account ending with 0018, for the County Administrator, the Finance Director and the Accounting Services Lead, all accounts associated with Dodge County are granted authority for handling banking operations; and

**NOW THEREFORE BE IT RESOLVED**, that this resolution can be modified at any time by the Dodge County Board and takes effect immediately upon the resolution being adopted, and will be recognized as the standing resolution for all future authorized signer changes.

*Resolution Adopted [Unanimous]*

**Bills Reviewed**

Mr. Venenga reviewed bills with the Board.

Motion by Tjosaas seconded by Toquam to approve the bills as discussed in the following amounts from the appropriate funds as determined by Finance:

01 Revenue Fund	\$ 85,439.93
13 Road and Bridge Fund	\$ 128,137.17
16 Environmental Quality Fund	\$ 91,778.28
52 The Midway	\$ 174.00
80 Agency Fund	\$ <u>2,533.93</u>
Total	\$ 308,063.31

*Motion Adopted [Unanimous]*

**Paul Kiltinen, County Attorney****Legal Update**

Mr. Kiltinen provided the Board with a legal update.

*Motion No Vote*

**Public Health Committee Report - Commissioner Rhonda Toquam**

Commissioner Toquam presented a summary of the Public Health Committee report and action items.

**Request to Approve Public Health Donations**

This is a request to accept baby boy bundles from Bundles of Love, Rochester, MN.

Commissioner Toquam offered the following resolution (#2026-07), seconded by Commissioner Tjosaas:

**WHEREAS**, the Dodge County Public Health Department has received donations from Bundles of Love; and

**WHEREAS**, the Dodge County Public Health Department wishes to accept this donation and utilize it for the purpose of distributing to family home visiting clients; and

**WHEREAS**, pursuant to Minnesota Statute 465.03, the county shall by resolution of the governing body adopted by a two-thirds majority of its members accept a grant or devise of real or personal property and maintain such property for the benefit of its citizens in accordance with the terms prescribed by the donor.

**NOW THEREFORE BE IT RESOLVED**, that the Dodge County Board of Commissioners hereby accepts the following donation to be used for the Public Health Programs:

Bethel Lutheran Church, Rochester, MN \$800.00  
Boys winter bundle: Diaper bag, outfits, blankets, baby care products, etc. (4)

*Resolution Adopted [Unanimous]*

**Public Health Update**

The Public Health Director provide an update during the Public Health Committee meeting on low potency retailer licensing and registrations as they are starting to learn of new licenses being issued within the county.

During the committee meeting Ms. Evans also provided an update on staffing and general operations.

*Motion No Vote*

**Administration Committee Report - Commissioner David Kenworthy**

Commissioner Kenworthy presented a summary of the Administration Committee report and action items.

Commissioners provided their agency reports. Commissioner Allen was not available to report his meeting attendance. Commissioner Kenworthy attended an annual SEECB meeting, a Public Works Committee meeting and an Administration Committee meeting. Commissioner Peterson didn't have any meetings to report. Commissioner Tjosaas attended a virtual MnPrairie Personnel Committee meeting. Commissioner Toquam attended a SCHA Compliance meeting, a MNPrairie Policy Committee meeting and a County Board meeting.

*Motion No Vote*

There were no Other Deferred Business items to discuss.

*Motion No Vote*

**Adjourn**

**Meeting Adjourned**

Motion by Tjosaas seconded by Toquam to adjourn the meeting at 9:49 a.m.

The next meeting of the Dodge County Board of Commissioners will be held on February 24, 2026 at 5:00 p.m.

*Motion Adopted [Unanimous]*

# MANTORVILLE FIRE DEPARTMENT

## March 2026 General Meeting

### Call to Order:

- The meeting was called to order at: 19:30

### Members in Attendance:

- Dave, Paul, Russ, Scott, Nate, Joey, Troy, Brett, Annabelle,, Duke, Nate, Orion, Ryan, Angel

### Chief's Report:

- Byron Social - March 18 - 18:00
- Social for Byron/Kasson/Mantorville
- Chief will be out of town March 25 - April 4
- Thank for escort yesterday - Boy's hockey - Troy, Nate B
- Nate S will be taking a student to school on Friday for the PTA fundraiser
- City has asked for review of the fee schedule, we billed a Fire Call and CO call this last month
- Lions Club providing supper in May
- PERA Annual Service Report Submitted
- Quarry Explosives being stored on site

### Assistant Chief:

- Nothing to report

### Fire Marshall:

- Nothing to report

### Training Officer:

- Riverland Sectional School - end of the month, Ryan to attend Officer training

### EMR Officer:

- SEEMs - Lucas training

### Equipment:

- Ice Rescue suit received
- Turn outs ordered have arrived
- 15 SCBA bottles HydroTested

### Vehicles:

- Betsy- In our Shed -
- Pumper 1- Windshield washer crack, seat not working
- Pumper 2 -
- Chevy Pick Up - Wipe blades needed

- Tanker 1 - Auto chains not working
- Tanker 2 -
- Grass Rig -
- Rescue Truck -

**Treasurer**

- 1806.31, Troy to approve, Annabelle to second - passed

**New Business:**

- Golf board having an anniversary part and asked us to rent the stage, use the snow fence and have members staff the gate on August 1st - members support was noted

**Old Business:**

- None

**Active Committees:**

- OSHA/Safety and Accountability: Russ, Nate S, Kitzy
- Radios: Paul, Ryan, Duke
- SOG'S/Personnel: Duke, Dave, Annabelle, Paul, Logan, Troy
- Uniform's: Orion, Annabelle, Nate S., Ryan, Troy - to meet
- Explorer program: Nate B., Nate S., Duke
- Truck/Equipment- Paul, Nate B., Joey, Nate S., Orion - see above
- Grants- Duke, Nate S., Ryan, Annabelle

**Point Report:**

- Motion made by: Russ
- 2nd by: Ryan
- Motion approved.

**Calendar:**

- March 18th 18:00 - Byron Hall
- March 25th 18:30 - Training
- April 1st
  - 1830 Maintenance
  - 1900 Meal (Duke & Brett)
- April 8th 18:30 - Medical Training
- April 15th 18:30 - Fire/Rescue Training

Meeting Adjourned at 19:56

# Mantorville Chamber of Commerce

February 4, 2026

The February meeting of the Mantorville Chamber of Commerce was call to order by meeting Co. President Brittney Wilcox at 8:00am on February 4, 2026.

Those in attendance were, Janice Borgstrom Durst, Kim Boyum, Brittney Wilcox, Lisa Manthes(Alerus), Jay Greistharot(John Buckingham Reality), Alexa Nash, Wendy Siewert(City), Lynnette Nash, Jinni Cormack, Kate Brickner, Lois Hancock, Paul Larsen, Jason K. and Barbara Loquai

**Secretary's Report:** Minutes were emailed to each member. Motion made by Janice Borgstrom Durst, and accept the minutes and seconded by Ginny Cormack. Motion Passed.

**Treasures Report** – Lynnette Nash passed out the treasure report. The report was from January 2025 to 2-23-2026 All the cookie tins were sold. License to the Dept. of Ag for Farmers market. She also reported on Special Event License – 3. Motion made by Paul Larsen and seconded by Jason K. to accept the treasure report as presented. Motion Passed.

**Old Business** – Annual was canceled in January do to the passing of long-time chamber members, Lyle Hoaglund and Marlyn Lermon. The dinner will be held February 12<sup>th</sup> at the Hubbell House Stagecoach room. Ticket are still available until Feb. 11<sup>th</sup>. Speak will be Jane Hardwick, Dodge County Community Foundation.

Dues are due. Election of officers will be at the March meeting.

**New Business** -The Dodge County Expo – March 28<sup>th</sup>. The cost of the both is \$125.00. In the past the chamber has had 2 booths. Motion made by Barbara Loquai to have 2 booths at the total of \$250.00 again this year and seconded by Janice Borgstrom Durst. Moton passed.

Easter Egg Hunt – The easter egg hunt will be held April 4, 2026 at Riverside Park. At the next meeting more information will be given and work dates setup to prepare for this event. The budget for the treat bags was presented. Paul Larsen made the motion to spend \$500.00 for the items for the bags and Seconded by Jancie BorgstromDurst. Motion passed.

An events committee was set up. This committee will me Tuesday February 17, 2026 at 9:00am at the Greek Revival House. Committee members Paul Larsen, Lisa Manthis, Barbara Loquai, Emma Bassness, Jennifer Galloway, Alexa Nash. And Jay Geisthardt.

No more business to come before this meeting. Meeting adjourned.

Secretary Barbara Loquai

Payments

Current Period: February 2026

Payments Batch 021826PAY FD Truck		\$147,144.32		
Refer	0 Sleepy Hollow Ford Inc.	-		
Cash Payment	E 102-42200-570 Capital Outlay	2026 Grass Rig Purchase		\$92,580.00
Invoice	02132026 2/18/2026		Project 25-009	
Transaction Date	2/18/2026	MBT Bank Checking 10100	<b>Total</b>	\$92,580.00
Refer	0 L & L Street Rod & Sport Truck	-		
Cash Payment	E 102-42200-570 Capital Outlay	2026 Grass Rig Purchase		\$54,564.32
Invoice	4549 2/18/2026		Project 25-009	
Transaction Date	2/18/2026	MBT Bank Checking 10100	<b>Total</b>	\$54,564.32

Fund Summary

	10100 MBT Bank Checking	
102 FIRE DEPARTMENT		\$147,144.32
		\$147,144.32

Pre-Written Checks	\$0.00
Checks to be Generated by the Computer	\$147,144.32
<b>Total</b>	<b>\$147,144.32</b>

Payments

Current Period: January 2026

<b>Payments Batch 013126PAY Resnex</b>		<b>\$79.95</b>	
Refer	0 RESNEXUS	-	
Cash Payment	E 603-45183-210 Tax and Licensing	Fees for January 2026	\$79.95
Invoice	010526	1/31/2026	
Transaction Date	2/25/2026	MBT Bank Checking 10100	<b>Total \$79.95</b>

Fund Summary

	10100 MBT Bank Checking	
603 RV PARK		\$79.95
		<u>\$79.95</u>

Pre-Written Checks	\$0.00
Checks to be Generated by the Computer	\$79.95
Total	<u>\$79.95</u>

Payments

Current Period: February 2026

Payments Batch 022726PAY		\$6,205.41	
Refer	0 CHASE CARD SERVICES	<u>2/27/2026</u>	
Cash Payment	E 101-41500-322 Postage	Postage for February 2026 Water Bills	\$78.00
Invoice	02/14/26 2/27/2026		
Cash Payment	E 604-43150-352 Publishing	Postage for February 2026 Water Bills	\$9.76
Invoice	02/14/26 2/27/2026		
Cash Payment	E 601-49400-430 Miscellaneous	Postage for February 2026 Water Bills	\$75.64
Invoice	02/14/26 2/27/2026		
Cash Payment	E 602-49450-437 Other Miscellaneous	Postage for February 2026 Water Bills	\$158.60
Invoice	02/14/26 2/27/2026		
Transaction Date	2/27/2026	MBT Bank Checking 10100	<b>Total</b> \$322.00
Refer	0 MN PERA	<u>Ck# 006820 2/27/2026</u>	
Cash Payment	G 101-21704 PERA	PR 4 2026	\$1,460.32
Invoice	02/20/2026 2/27/2026		
Transaction Date	2/27/2026	MBT Bank Checking 10100	<b>Total</b> \$1,460.32
Refer	0 RESNEXUS	<u>2/27/2026</u>	
Cash Payment	E 603-45183-210 Tax and Licensing	February Billing	\$50.25
Invoice	717192 2/27/2026		
Transaction Date	2/27/2026	MBT Bank Checking 10100	<b>Total</b> \$50.25
Refer	0 WEX HEALTH, INC.	<u>2/22/1966</u>	
Cash Payment	E 101-41500-300 Professional Srvs (GEN	February Billing	\$11.00
Invoice	0002314095-IN 2/27/2026		
Transaction Date	2/27/2026	MBT Bank Checking 10100	<b>Total</b> \$11.00
Refer	0 MINNESOTA REVENUE	<u>Ck# 006822 2/27/2026</u>	
Cash Payment	G 101-21702 State Withholding	PR 4 2026	\$467.16
Invoice	02/19/26 2/27/2026		
Transaction Date	2/27/2026	MBT Bank Checking 10100	<b>Total</b> \$467.16
Refer	0 INTERNAL REVENUE SERVICE	<u>Ck# 006821 2/27/2026</u>	
Cash Payment	G 101-21703 FICA Tax Withholding	PR 4 2026	\$1,182.30
Invoice	02/19/26 2/27/2026		
Cash Payment	G 101-21709 Medicare	PR 4 2026	\$276.50
Invoice	02/19/26 2/27/2026		
Cash Payment	G 101-21701 Federal Withholding	PR 4 2026	\$814.12
Invoice	02/19/26 2/27/2026		
Transaction Date	2/27/2026	MBT Bank Checking 10100	<b>Total</b> \$2,272.92
Refer	0 WEX HEALTH, INC.	<u>Ck# 006819 2/27/2026</u>	
Cash Payment	G 101-21714 Health Savings Account	PR 4 2026 ER	\$253.84
Invoice	02/19/26 2/27/2026		
Cash Payment	G 101-21714 Health Savings Account	PR 4 2026 EE	\$190.00
Invoice	02/19/26 2/27/2026		
Transaction Date	2/27/2026	MBT Bank Checking 10100	<b>Total</b> \$443.84
Refer	0 WEX HEALTH, INC.	<u>Ck# 006818 2/27/2026</u>	
Cash Payment	G 101-21714 Health Savings Account	PR 3 2026 ER	\$253.84
Invoice	02/05/26 2/27/2026		
Cash Payment	G 101-21714 Health Savings Account	PR 3 2026 EE	\$190.00
Invoice	02/05/26 2/27/2026		

MANTORVILLE, MN

02/27/26 10:23 AM

Page 2

Payments

Current Period: February 2026

Transaction Date	2/27/2026	MBT Bank Checking 10100	<b>Total</b>	<b>\$443.84</b>
Refer	0 XCEL ENERGY	2/27/2026		
Cash Payment	E 101-43160-381 Electric Utilities	39 W LED PUR OPTN		\$69.36
Invoice	965495728	2/27/2026		
Transaction Date	2/27/2026	MBT Bank Checking 10100	<b>Total</b>	<b>\$69.36</b>
Refer	0 DELTA DENTAL	2/27/2026		
Cash Payment	G 101-21708 Dental Insurance	March 2026 Coverage		\$180.72
Invoice	RIS0006889873	2/27/2026		
Transaction Date	2/27/2026	MBT Bank Checking 10100	<b>Total</b>	<b>\$180.72</b>
Refer	0 NCPERS GROUP LIFE INS.	2/27/2026		
Cash Payment	G 101-21711 Life Insurance Payable	Coverage for March 2026		\$32.00
Invoice	608900032026	2/27/2026		
Transaction Date	2/27/2026	MBT Bank Checking 10100	<b>Total</b>	<b>\$32.00</b>
Refer	0 SIMPLY TIDY, LLC	2/27/2026		
Cash Payment	E 101-41940-439 Janitors	Cleaning for January		\$130.00
Invoice	7273	2/27/2026		
Transaction Date	2/27/2026	MBT Bank Checking 10100	<b>Total</b>	<b>\$130.00</b>
Refer	0 US POSTAL SERVICE	Ck# 006827 2/27/2026		
Cash Payment	E 604-43150-352 Publishing	For March Water Bills 2026		\$9.76
Invoice	022726	2/27/2026		
Cash Payment	E 601-49400-430 Miscellaneous	For March Water Bills 2026		\$75.64
Invoice	022726	2/27/2026		
Cash Payment	E 602-49450-437 Other Miscellaneous	For March Water Bills 2026		\$158.60
Invoice	022726	2/27/2026		
Cash Payment	E 101-41500-322 Postage	For March Water Bills 2026		\$78.00
Invoice	022726	2/27/2026		
Transaction Date	2/27/2026	MBT Bank Checking 10100	<b>Total</b>	<b>\$322.00</b>

Fund Summary

	10100 MBT Bank Checking	
101 GENERAL FUND		\$5,667.16
601 WATER FUND		\$151.28
602 SEWER FUND		\$317.20
603 RV PARK		\$50.25
604 STORM SEWER FUND		\$19.52
		<u>\$6,205.41</u>

Pre-Written Checks	\$5,410.08
Checks to be Generated by the Computer	\$795.33
Total	<u>\$6,205.41</u>

Payments

Current Period: December 2025

<b>Payment Batch 123125PAY Door</b>		<b>\$7,660.00</b>
Refer	0 ROCHESTER PLUMBING & HEATIN _	
Cash Payment	E 601-49400-570 Capital Outlay	Water Meter for City Hall \$2,800.00
Invoice	164313R#1	12/31/2025
Cash Payment	E 601-49400-220 Bldg.Repair and Mainten	Water Meter for City Hall \$4,200.00
Invoice	164313R#1	12/31/2025
Cash Payment	E 101-41940-220 Bldg.Repair and Mainten	Water Meter for City Hall \$660.00
Invoice	164313R#1	12/31/2025
Transaction Date	3/4/2026	MBT Bank Checking 10100 <b>Total</b> \$7,660.00

Fund Summary

	10100 MBT Bank Checking	
101 GENERAL FUND		\$660.00
601 WATER FUND		\$7,000.00
		<u>\$7,660.00</u>

Pre-Written Checks	\$0.00
Checks to be Generated by the Computer	\$7,660.00
Total	<u>\$7,660.00</u>

MANTORVILLE, MN

03/06/26 2:16 PM

Page 1

Payments

Current Period: March 2026

Payments Batch 030626PAY		\$44,795.88	
Refer	0 SOUTHEAST SERVICE COOPERAT	Ck# 006817	3/9/2026
Cash Payment	G 101-21706 Hospitalization/Medical Ins	Service for March 2026	\$3,765.28
Invoice	03/01/26	3/9/2026	
Transaction Date	3/6/2026	MBT Bank Checking 10100	<b>Total</b> \$3,765.28
Refer	0 MINNESOTA REVENUE	Ck# 006832	3/9/2026
Cash Payment	G 101-21702 State Withholding	PR 5 2026	\$451.75
Invoice	03/03/26	3/9/2026	
Transaction Date	3/6/2026	MBT Bank Checking 10100	<b>Total</b> \$451.75
Refer	0 INTERNAL REVENUE SERVICE	Ck# 006831	3/9/2026
Cash Payment	G 101-21703 FICA Tax Withholding	PR 5 2026	\$1,151.14
Invoice	3/3/26	3/9/2026	
Cash Payment	G 101-21709 Medicare	PR 5 2026	\$269.22
Invoice	3/3/26	3/9/2026	
Cash Payment	G 101-21701 Federal Withholding	PR 5 2026	\$785.16
Invoice	3/3/26	3/9/2026	
Transaction Date	3/6/2026	MBT Bank Checking 10100	<b>Total</b> \$2,205.52
Refer	0 PAYMENT SERVICE NETWORK, IN	Ck# 006830	3/9/2026
Cash Payment	E 602-49450-300 Professional Srvs (GEN	Services for February 2026	\$112.22
Invoice	02/01/26	3/9/2026	
Cash Payment	E 601-49400-300 Professional Srvs (GEN	Services for February 2026	\$60.43
Invoice	02/01/26	3/9/2026	
Transaction Date	3/6/2026	MBT Bank Checking 10100	<b>Total</b> \$172.65
Refer	0 MN PERA	Ck# 006829	3/9/2026
Cash Payment	G 101-21704 PERA	PR 5 2026	\$1,422.71
Invoice	03/04/26	3/9/2026	
Transaction Date	3/6/2026	MBT Bank Checking 10100	<b>Total</b> \$1,422.71
Refer	0 ROCHESTER PLUMBING & HEATIN	-	
Cash Payment	E 101-41940-220 Bldg.Repair and Mainten	Install Water Supply to Eyewash Station	\$585.00
Invoice	164313R#2	3/9/2026	
Transaction Date	3/6/2026	MBT Bank Checking 10100	<b>Total</b> \$585.00
Refer	0 DURST OUTDOOR SERVICES	-	
Cash Payment	E 101-43100-570 Capital Outlay	2026 Street Sweeping	\$3,345.00
Invoice	4025	3/9/2026	
Transaction Date	3/6/2026	MBT Bank Checking 10100	<b>Total</b> \$3,345.00
Refer	0 DODGE COUNTY INDEPENDENT	-	
Cash Payment	E 101-41110-352 Publishing	Public Notice - City Council Vacancy	\$37.05
Invoice	20462	3/9/2026	
Transaction Date	3/6/2026	MBT Bank Checking 10100	<b>Total</b> \$37.05
Refer	0 AFLAC	3/9/2026	
Cash Payment	G 101-21710 AFLAC	February 28th Billing	\$33.12
Invoice	187325	3/9/2026	
Transaction Date	3/6/2026	MBT Bank Checking 10100	<b>Total</b> \$33.12
Refer	0 MINNESOTA ENERGY	-	

MANTORVILLE, MN

03/06/26 2:16 PM

Page 2

Payments

Current Period: March 2026

Cash Payment	E 101-41940-380	Utility Services	4016467-5 STREETS (1008 East St - East Bldg)	\$708.22
Invoice	5810441098	3/9/2026		
Cash Payment	E 101-41940-380	Utility Services	4300149-4 STREETS (1008 East St - Middle Bldg)	\$453.85
Invoice	5810441098	3/9/2026		
Cash Payment	E 101-41940-380	Utility Services	4028156-0 STREETS (1008 East St - West Bldg)	\$380.05
Invoice	5810441098	3/9/2026		
Cash Payment	E 101-42200-380	Utility Services	4229566-7 FIRE DEPT (21 5th St E)	\$631.75
Invoice	5810441098	3/9/2026		
Cash Payment	E 602-49450-380	Utility Services	4299022-6 WWTP (121 Blanch St)	\$416.66
Invoice	5810441098	3/9/2026		
Transaction Date	3/6/2026		MBT Bank Checking 10100	<b>Total</b> \$2,590.53
Refer	0	MN DEPARTMENT OF HEALTH	-	
Cash Payment	E 601-49400-441	MDH FEE	Qtr. 1 MDH Fee 2026	\$1,605.00
Invoice	Qtr1	3/9/2026		
Transaction Date	3/6/2026		MBT Bank Checking 10100	<b>Total</b> \$1,605.00
Refer	0	SOUTHEAST SERVICE COOPERAT	-	
Cash Payment	E 101-41500-120	Benefits	EAP Wellness Pool for 2026	\$384.00
Invoice	SINV000006867	3/9/2026		
Transaction Date	3/6/2026		MBT Bank Checking 10100	<b>Total</b> \$384.00
Refer	0	MN PERA	-	
Cash Payment	E 101-42200-124	Fire Pension Contributio	Annual Municipal 2026 Contribution to Pera	\$4,000.00
Invoice	1013	3/9/2026		
Transaction Date	3/6/2026		MBT Bank Checking 10100	<b>Total</b> \$4,000.00
Refer	0	JACOBSEN LAW FIRM, P.A.	-	
Cash Payment	E 101-41600-304	Legal Fees	Service for January	\$616.00
Invoice	4898	3/9/2026		
Cash Payment	E 101-41600-304	Legal Fees	Service for February	\$923.00
Invoice	4933	3/9/2026		
Transaction Date	3/6/2026		MBT Bank Checking 10100	<b>Total</b> \$1,539.00
Refer	0	BLUE CROSS BLUE SHIELD OF MI	-	
Cash Payment	G 101-21715	Employee Paid Vision Plan	Service for March 2026	\$23.40
Invoice	260202230272	3/9/2026		
Transaction Date	3/6/2026		MBT Bank Checking 10100	<b>Total</b> \$23.40
Refer	0	ON-SITE COMPUTERS, INC	-	
Cash Payment	E 101-41500-300	Professional Srvs (GEN	Services for February	\$334.39
Invoice	CW106044	3/9/2026		
Transaction Date	3/6/2026		MBT Bank Checking 10100	<b>Total</b> \$334.39
Refer	0	DODGE COUNTY HIGHWAY DEPA	-	
Cash Payment	E 101-43125-406	Snow/Ice Removal	Salt & Sand	\$1,239.27
Invoice	828	3/9/2026		
Transaction Date	3/6/2026		MBT Bank Checking 10100	<b>Total</b> \$1,239.27
Refer	0	WHKS & COMPANY	-	
Cash Payment	E 602-49450-303	Engineering Fees	CSAH for January Lift Station	\$419.20
Invoice	56863	3/9/2026		
			Project 23-001	

# MANTORVILLE, MN

03/06/26 2:16 PM

Page 3

## Payments

Current Period: March 2026

Transaction Date	3/6/2026	MBT Bank Checking	10100	<b>Total</b>	<b>\$419.20</b>
Refer	0 LEAGUE OF MINNESOTA CITIES	-			
Cash Payment	E 101-43100-229	Safety/OSHA	2026 Safety Groups Training		\$819.00
Invoice	445541	3/9/2026			
Transaction Date	3/6/2026	MBT Bank Checking	10100	<b>Total</b>	<b>\$819.00</b>
Refer	0 KENNEDY & GRAVEN, CHARTERE	-			
Cash Payment	E 101-41600-304	Legal Fees	Service through January		\$1,143.40
Invoice	192041	3/9/2026			
Transaction Date	3/6/2026	MBT Bank Checking	10100	<b>Total</b>	<b>\$1,143.40</b>
Refer	0 CMS - CONSTRUCTION MGMT. SE	-			
Cash Payment	E 101-42400-300	Professional Srvs (GEN	Fees for January		\$225.00
Invoice	817-265285-1	3/9/2026			
Transaction Date	3/6/2026	MBT Bank Checking	10100	<b>Total</b>	<b>\$225.00</b>
Refer	0 DODGE COUNTY SHERIFF	-			
Cash Payment	E 101-42100-310	Other Professional Servi	Sheriff Contract for 2026		\$9,533.33
Invoice	March	3/9/2026			
Transaction Date	3/6/2026	MBT Bank Checking	10100	<b>Total</b>	<b>\$9,533.33</b>
Refer	0 BADGER METER	-			
Cash Payment	E 601-49400-300	Professional Srvs (GEN	Services for February 2026		\$152.98
Invoice	80228008	3/9/2026			
Cash Payment	E 602-49450-300	Professional Srvs (GEN	Services for February 2026		\$284.12
Invoice	80228008	3/9/2026			
Transaction Date	3/6/2026	MBT Bank Checking	10100	<b>Total</b>	<b>\$437.10</b>
Refer	0 XCEL ENERGY	-			
Cash Payment	E 101-43160-381	Electric Utilities	STREET LIGHTS		\$1,839.24
Invoice	966117892	3/9/2026			
Cash Payment	E 101-43160-381	Electric Utilities	300 MAIN N BRIDGE LIGHTS		\$21.78
Invoice	966117892	3/9/2026			
Cash Payment	E 101-43160-381	Electric Utilities	130 ST.HWY 57 S.CITY SIGN		\$4.10
Invoice	966117892	3/9/2026			
Cash Payment	E 101-43160-381	Electric Utilities	60003 ST.HWY 57 N CITY SIGN		\$10.37
Invoice	966117892	3/9/2026			
Cash Payment	E 101-42200-380	Utility Services	21 5TH STREET SIREN		\$6.86
Invoice	966117892	3/9/2026			
Cash Payment	E 101-42200-380	Utility Services	21 5TH STREET E FH/CH/PUMP		\$218.93
Invoice	966117892	3/9/2026			
Cash Payment	E 101-42200-380	Utility Services	701 CHESTNUT SIREN		\$7.04
Invoice	966117892	3/9/2026			
Cash Payment	E 101-43160-381	Electric Utilities	410 CLAY POLE ON EDA LOT		\$11.48
Invoice	966117892	3/9/2026			
Cash Payment	E 101-41940-380	Utility Services	600 7TH STREET WEST MANTORFIEL		\$39.66
Invoice	966117892	3/9/2026			
Cash Payment	E 101-41940-380	Utility Services	340 CLAY RIVERSIDE W CENTER		\$24.22
Invoice	966117892	3/9/2026			
Cash Payment	E 101-41940-380	Utility Services	342 MAIN ST N RIVERSIDE NE		\$10.69
Invoice	966117892	3/9/2026			

MANTORVILLE, MN

03/06/26 2:16 PM

Page 4

Payments

Current Period: March 2026

Cash Payment	E 101-41940-380	Utility Services	601 GOLFVIEW DENNISON FIELD	\$13.25
Invoice	966117892	3/9/2026		
Cash Payment	E 101-41940-380	Utility Services	1008 EAST CITY SHOP	\$149.60
Invoice	966117892	3/9/2026		
Cash Payment	E 602-49450-380	Utility Services	121 BLANCH WWTF+SEC+PUMP	-\$287.52
Invoice	966117892	3/9/2026		
Cash Payment	E 601-49400-380	Utility Services	841 BLANCH WTR WELL HOUSE	\$666.69
Invoice	966117892	3/9/2026		
Cash Payment	E 601-49400-380	Utility Services	924 JEFFERSON WATER TOWER	\$9.41
Invoice	966117892	3/9/2026		
Cash Payment	E 603-45183-381	Electric Utilities	324 MAIN ST N CAMPGROUND	-\$68.88
Invoice	966117892	3/9/2026		
Cash Payment	E 101-41940-380	Utility Services	101 BLANCH NEW SHOP	\$0.00
Invoice	966117892	3/9/2026		
Cash Payment	E 101-41940-380	Utility Services	15 4TH STREET WEST RIVERSIDE	\$11.48
Invoice	966117892	3/9/2026		
Cash Payment	E 602-49450-380	Utility Services	601 JEFFERSON LIFT STATION	\$22.02
Invoice	966117892	3/9/2026		
Cash Payment	E 602-49450-380	Utility Services	121 BLANCH AUTO PROTECT LIGHT	\$11.11
Invoice	966117892	3/9/2026		
Cash Payment	E 101-43160-381	Electric Utilities	CHRISTMAS LIGHTS	\$0.00
Invoice	966117892	3/9/2026		
Cash Payment	E 101-41940-380	Utility Services	300 CLAY ST	\$10.69
Invoice	966117892	3/9/2026		
Cash Payment	E 602-49450-380	Utility Services	404 Main St. N Unity Street Lights	\$18.36
Invoice	966117892	3/9/2026		
Transaction Date	3/6/2026		MBT Bank Checking 10100	<b>Total</b> \$2,750.58
Refer	0	MAXSON ELECTRIC	-	
Cash Payment	E 101-41940-220	Bldg.Repair and Mainten	2/17 located wires, wired water meter	\$271.84
Invoice	7567	3/9/2026		
Transaction Date	3/6/2026		MBT Bank Checking 10100	<b>Total</b> \$271.84
Refer	0	ADAMS, JOE	-	
Cash Payment	E 101-45200-401	Repairs/Maint Buildings	Large Wooden Crate 87x5x7	\$153.77
Invoice	2/23/26	3/9/2026		
Transaction Date	3/6/2026		MBT Bank Checking 10100	<b>Total</b> \$153.77
Refer	0	HAWKINS, INC	3/9/2026	
Cash Payment	E 601-49400-216	Chemicals and Chem Pr	150 lb Chlorine Cylinder(s)	\$20.00
Invoice	7334819	3/9/2026		
Transaction Date	3/6/2026		MBT Bank Checking 10100	<b>Total</b> \$20.00
Refer	0	ROCHESTER OVERHEAD DOOR IN	-	
Cash Payment	E 101-41940-220	Bldg.Repair and Mainten	Sensors for Door	\$440.00
Invoice	34468	3/9/2026		
Transaction Date	3/6/2026		MBT Bank Checking 10100	<b>Total</b> \$440.00
Refer	0	DECOOK DRAINAGE	-	
Cash Payment	E 101-43125-406	Snow/Ice Removal	Snow Removal for January 2026	\$556.10
Invoice	7688	3/9/2026		
Transaction Date	3/6/2026		MBT Bank Checking 10100	<b>Total</b> \$556.10

MANTORVILLE, MN

03/06/26 2:16 PM

Page 5

Payments

Current Period: March 2026

Refer	0 METERING & TECHNOLOGY SOLU			-	
Cash Payment	E 601-49400-228	Equip. Repair and Maint	Cellular Lte Endpoint		\$154.06
Invoice	INV9910	3/9/2026			
Transaction Date	3/6/2026	MBT Bank Checking	10100	<b>Total</b>	\$154.06
Refer	0 KMTELECOM			-	
Cash Payment	E 101-41940-321	Communications Phone/	CITY HALL MAIN 5170		\$124.90
Invoice	10308119	3/9/2026			
Cash Payment	E 101-41940-321	Communications Phone/	CITY HALL - 5176 - 2ND LINE		\$20.91
Invoice	10308119	3/9/2026			
Cash Payment	E 601-49400-321	Communications Phone/	NEW WELL HOUSE FIBER		\$25.00
Invoice	10308119	3/9/2026			
Cash Payment	E 101-42200-321	Communications Phone/	FD 5440		\$25.90
Invoice	10308119	3/9/2026			
Cash Payment	E 101-41940-321	Communications Phone/	STREETS - SHOP 5119		\$97.88
Invoice	10308119	3/9/2026			
Cash Payment	E 601-49400-321	Communications Phone/	WATER TOWER ALARM 3588		\$46.58
Invoice	10308119	3/9/2026			
Cash Payment	E 602-49450-321	Communications Phone/	LIFT STATION ALARM 5066		\$36.58
Invoice	10308119	3/9/2026			
Cash Payment	E 602-49450-321	Communications Phone/	WWTP 5463 ALARM		\$36.58
Invoice	10308119	3/9/2026			
Cash Payment	E 101-41940-321	Communications Phone/	LONG DISTANCE/TAXES/FEES		\$5.85
Invoice	10308119	3/9/2026			
Cash Payment	E 101-46500-437	Other Miscellaneous	EDA 800 NUMBER		\$0.00
Invoice	10308119	3/9/2026			
Transaction Date	3/6/2026	MBT Bank Checking	10100	<b>Total</b>	\$420.18
Refer	0 WARSAW SOLAR, LLC			-	
Cash Payment	E 603-45183-381	Electric Utilities	Power Sales for January		\$90.85
Invoice	2602-6994D	3/9/2026			
Cash Payment	E 101-43160-381	Electric Utilities	Power Sales for January		\$794.91
Invoice	2602-6994D	3/9/2026			
Cash Payment	E 101-41940-380	Utility Services	Power Sales for January		\$363.39
Invoice	2602-6994D	3/9/2026			
Cash Payment	E 101-42200-380	Utility Services	Power Sales for January		\$249.83
Invoice	2602-6994D	3/9/2026			
Cash Payment	E 602-49450-380	Utility Services	Power Sales for January		\$454.23
Invoice	2602-6994D	3/9/2026			
Cash Payment	E 601-49400-380	Utility Services	Power Sales for January		\$317.96
Invoice	2602-6994D	3/9/2026			
Transaction Date	3/6/2026	MBT Bank Checking	10100	<b>Total</b>	\$2,271.17
Refer	0 ULTIMATE SAFETY CONCEPTS, IN			-	
Cash Payment	E 101-42200-217	Other Operating Supplie	Cold Water Rescue Suit		\$907.21
Invoice	221095	3/9/2026			
Transaction Date	3/6/2026	MBT Bank Checking	10100	<b>Total</b>	\$907.21
Refer	0 FIRE SAFETY USA, INC			-	
Cash Payment	E 101-42200-217	Other Operating Supplie	Fire Cap Plus, 5 Gallon Pail		\$299.90
Invoice	252907	3/9/2026			
Transaction Date	3/6/2026	MBT Bank Checking	10100	<b>Total</b>	\$299.90

Payments

Current Period: March 2026

Refer	0	BOUND TREE MEDICAL, LLC	-		
Cash Payment	E 101-42200-311	First Responder Train/E	AED Pads		\$227.97
Invoice	86108457	3/9/2026			
Transaction Date	3/6/2026		MBT Bank Checking	10100	<b>Total</b> \$227.97
Refer	0	CULLIGAN GREATER ROCHESTER	-		
Cash Payment	E 101-41940-200	Supplies	Bottled Water February		\$12.40
Invoice	611X03162	3/9/2026			
Transaction Date	3/6/2026		MBT Bank Checking	10100	<b>Total</b> \$12.40

Fund Summary

	10100	MBT Bank Checking	
101 GENERAL FUND			\$40,192.24
601 WATER FUND			\$3,058.11
602 SEWER FUND			\$1,523.56
603 RV PARK			\$21.97
			<u>\$44,795.88</u>

Pre-Written Checks	\$8,017.91
Checks to be Generated by the Computer	\$36,777.97
Total	<u>\$44,795.88</u>

City **Mantorville**  
 Date **2/1/2026** thru **2/28/2026**

<u>Agency</u>	<u>Incident_Nr</u>	<u>Location</u>	<u>LocCity</u>	<u>Activity</u>
S	202600001212	1 5th St W	Mantorville	Req for Extra Patrol
S	202600000881	102 Main St N	Mantorville	Disturbance
S	202600001251	1109 7th St W	Mantorville	Ambulance Run
TRN	202600000002	22 6th St E	Mantorville	TeST Only-No Resp Needed
TRN	202600000018	22 6th St E	Mantorville	Suspicious Activity
TRN	202600000019	22 6th St E	Mantorville	TeST Only-No Resp Needed
TRN	202600000020	22 6th St E	Mantorville	TeST Only-No Resp Needed
TRN	202600000024	22 6th St E	Mantorville	Homicide
K	202600000428	22 6th St E	Mantorville	Assist Other Agency
S	202600000792	22 6th St E	Mantorville	Civil
S	202600000867	22 6th St E	Mantorville	Emergency Risk OFP
S	202600000927	22 6th St E	Mantorville	TeST Only-No Resp Needed
S	202600000928	22 6th St E	Mantorville	Motorist Assist
S	202600000955	22 6th St E	Mantorville	Violate/cond-release
S	202600001327	22 6th St E	Mantorville	Violate/cond-release
S	202600001329	22 6th St E	Mantorville	Ambulance Run
S	202600000745	22 6th St E	Mantorville	Admin. Stats Only
S	202600000747	22 6th St E	Mantorville	Admin. Stats Only
S	202600000748	22 6th St E	Mantorville	Admin. Stats Only
S	202600000749	22 6th St E	Mantorville	Permit To Purchase
S	202600000765	22 6th St E	Mantorville	Admin. Stats Only
S	202600000766	22 6th St E	Mantorville	Admin. Stats Only
S	202600000777	22 6th St E	Mantorville	Admin. Stats Only
S	202600000778	22 6th St E	Mantorville	Admin. Stats Only
S	202600000852	22 6th St E	Mantorville	Admin. Stats Only
S	202600000853	22 6th St E	Mantorville	Admin. Stats Only
S	202600000854	22 6th St E	Mantorville	Permit To Purchase
S	202600000856	22 6th St E	Mantorville	Permit To Purchase
S	202600000857	22 6th St E	Mantorville	Permit To Purchase
S	202600000858	22 6th St E	Mantorville	Permit To Purchase
S	202600000863	22 6th St E	Mantorville	Admin. Stats Only
S	202600000864	22 6th St E	Mantorville	Admin. Stats Only
S	202600000931	22 6th St E	Mantorville	Permit To Purchase
S	202600000939	22 6th St E	Mantorville	Permit To Purchase
S	202600000964	22 6th St E	Mantorville	Admin. Stats Only
S	202600000966	22 6th St E	Mantorville	Admin. Stats Only
S	202600000978	22 6th St E	Mantorville	Permit To Purchase
S	202600000999	22 6th St E	Mantorville	Permit To Purchase
S	202600001001	22 6th St E	Mantorville	Admin. Stats Only
S	202600001006	22 6th St E	Mantorville	Admin. Stats Only
S	202600001029	22 6th St E	Mantorville	Admin. Stats Only
S	202600001032	22 6th St E	Mantorville	Admin. Stats Only
S	202600001122	22 6th St E	Mantorville	Admin. Stats Only
S	202600001123	22 6th St E	Mantorville	Admin. Stats Only
S	202600001125	22 6th St E	Mantorville	Admin. Stats Only
S	202600001131	22 6th St E	Mantorville	Admin. Stats Only
S	202600001133	22 6th St E	Mantorville	Admin. Stats Only
S	202600001153	22 6th St E	Mantorville	Admin. Stats Only
S	202600001155	22 6th St E	Mantorville	Admin. Stats Only
S	202600001187	22 6th St E	Mantorville	Permit To Purchase
S	202600001191	22 6th St E	Mantorville	Admin. Stats Only
S	202600001195	22 6th St E	Mantorville	Admin. Stats Only
S	202600001202	22 6th St E	Mantorville	Admin. Stats Only
S	202600001206	22 6th St E	Mantorville	Admin. Stats Only
S	202600001208	22 6th St E	Mantorville	Admin. Stats Only
S	202600001209	22 6th St E	Mantorville	Permit To Purchase
S	202600001215	22 6th St E	Mantorville	Admin. Stats Only
S	202600001220	22 6th St E	Mantorville	Permit To Purchase
S	202600001261	22 6th St E	Mantorville	Admin. Stats Only

City **Mantorville**  
 Date **2/1/2026** thru **2/28/2026**

<u>Agency</u>	<u>Incident_Nr</u>	<u>Location</u>	<u>LocCity</u>	<u>Activity</u>
S	202600001262	22 6th St E	Mantorville	Admin. Stats Only
S	202600001265	22 6th St E	Mantorville	Admin. Stats Only
S	202600001267	22 6th St E	Mantorville	Admin. Stats Only
S	202600001268	22 6th St E	Mantorville	Admin. Stats Only
S	202600001298	22 6th St E	Mantorville	Admin. Stats Only
S	202600001299	22 6th St E	Mantorville	Admin. Stats Only
S	202600001300	22 6th St E	Mantorville	Admin. Stats Only
S	202600001312	22 6th St E	Mantorville	Admin. Stats Only
S	202600001357	22 6th St E	Mantorville	Paper Service
S	202600001214	404 Mantor Dr	Mantorville	Alarm
S	202600001033	408 Cemetery Rd	Mantorville	Public Assist
S	202600001234	414 6th St W	Mantorville	Miscellaneous
S	202600001072	414 6th St W	Mantorville	9-1-1 Hang Up Call
S	202600001222	414 6th St W	Mantorville	9-1-1 Hang Up Call
S	202600001362	501 Main St N	Mantorville	Dwi/3rd Degree
S	202600000839	502 Main St N	Mantorville	Ambulance Run
S	202600000884	502 Main St N	Mantorville	Open Door
S	202600001078	502 Main St N	Mantorville	Ambulance Run
S	202600001284	540 Main St N	Mantorville	Fraud
K	202600000501	610 Golfview Ct	Mantorville	Assist Other Agency
S	202600001045	610 Golfview Ct	Mantorville	Suspicious Activity
S	202600000769	620 6th St W	Mantorville	Paper Service
S	202600000992	623 Golfview Ct	Mantorville	Ambulance Run
S	202600001351	701 Blanch St	Mantorville	Public Assist
S	202600001381	701 Blanch St	Mantorville	Emergency Risk OFP
S	202600001387	701 Blanch St	Mantorville	Disturbance
S	202600001027	709 Chestnut St	Mantorville	Lost Property
S	202600000815	713 Chestnut St	Mantorville	Ambulance Run
S	202600001022	713 Chestnut St	Mantorville	Ambulance Run
S	202600001336	713 Chestnut St	Mantorville	Ambulance Run
S	202600001035	816 Main St N	Mantorville	Contempt Of Court
S	202600001344	817 Hickory Ln	Mantorville	Paper Service
S	202600000767	821 West St	Mantorville	Paper Service
S	202600001227	900BLK East St	Mantorville	Abandoned Vehicle

Total

93

**RESOLUTION 2026-08**  
**A RESOLUTION AUTHORIZING THE CERTIFICATION OF UNPAID CHARGES TO THE**  
**DODGE COUNTY AUDITOR**

WHEREAS, Chapter 50.03 of the Mantorville City Code establishes the process for collecting unpaid Water and Sewer bills; and Chapter 96 of the Mantorville City Code establishes the process for collecting unpaid Fire Call Fees, and

WHEREAS, pursuant to proper notice duly given and a chance to appeal, the following list attached, known as Exhibit A, encompasses those unpaid charges.

THEREFORE BE IT RESOLVED, by the City Council of the City of Mantorville, County of Dodge, State of Minnesota that the unpaid charges, attached as exhibit A, shall constitute a special assessment against the lands as listed and shall be certified to the Dodge County Auditor for collection with property taxes.

Passed by the Mantorville City Council this 9<sup>th</sup> day of March, 2026.

The City Clerk is instructed to transmit a copy of the assessments to Dodge County to be extended on the property tax lists of the County. Such assessments shall be collected and paid in the same manner as other municipal taxes.

---

Mayor Jeff Ingalls

---

Attest: Gretchen Lohrbach  
City Clerk Treasurer

**EXHIBIT A - PROPERTIES TO BE CERTIFIED**

**NAME                      PUD#                      ADDRESS                      AMOUNT**

**STORM WATER FEES OUTSTANDING**

**WATER SEWER BILLS OUTSTANDING**

**FIRE CALL FEES**

Maddox Fritz	25.100.0600	102 9 <sup>th</sup> Street West	\$500.00
--------------	-------------	---------------------------------	----------



**PAST DUE**  
**PLEASE REMIT PAYMENT**

**EMERGENCY RESPONSE INVOICE**

Invoice No.: 2025.0714.2  
Invoice Date: December 16, 2025

**TO:** Maddox Fritz  
102 9<sup>th</sup> St W  
Mantorville, MN 55955

**INSURANCE:** N/A

**DATE OF INCIDENT:** March 2, 2025

**LOCATION/TYPE OF INCIDENT:** Smoke Alarm

SERVICE PROVIDED	CHARGES
Investigated Smoke Alarm (No Smoke)	\$500.00
<b>TOTAL DUE UPON RECEIPT:</b>	<b>\$500.00</b>

Please make checks payable to:

City of Mantorville  
21 5<sup>th</sup> Street E  
PO Box 188  
Mantorville, MN 55955-0188

**Please return this portion with payment made payable to:**

City of Mantorville  
21 5<sup>th</sup> Street E, PO Box 188  
Mantorville, MN 55955

Maddox Fritz  
102 9<sup>th</sup> St W  
Mantorville, MN 55955

Seriously Past Due  
Invoice No. 2025.0714.2  
Original Invoice Date: July 14, 2025  
3rd Notice Past Due: December 16, 2025  
Total Due: \$500.00

---

# Memorandum

**To:** Mayor and City Council  
**From:** Gretchen Lohrbach  
**Date:** March 9, 2026  
**Re:** Garbage Hauler License Renewal

---

The following companies have applied for renewal of their garbage/refuse hauler licensing in the City of Mantorville for 2020:

Harter's Disposal of MN  
Waste Management  
LRS of MN, LLC  
Skjeveland Enterprises  
Aspen Waste Systems Inc.

Per City requirements, all must be licensed by Dodge County and have submitted certificates of insurance. All have met the requirements to operate in the City of Mantorville.

It is recommended that the City Council should approve the Renewals for Refuse Haulers License for 2026.

**CONFIDENTIAL**

# City of Mantorville Council/Committee Appointment Application Form

GL Received 3/2/26

Date 03.01.2026

## General Information

Name Kappers Jerrod LEE  
Last First MI

Address \_\_\_\_\_  
Street City State Zip

Phone Numbers: Home \_\_\_\_\_ Work \_\_\_\_\_  
Cell \_\_\_\_\_

Email Address: \_\_\_\_\_

## Council/Committees

If you wish to be considered for more than one committee or function, please number in order of preference.

City Council  
 Election Judge  
 Park Board  
 Economic Development Authority  
 Party Affiliation or  No Party  
(If applying for Election Judge)

## Special Interest

As the Council prioritizes its goals, it may create additional/new committees or task forces from time to time. If you have other specific areas or topics of interest, please indicate those interests and we will retain your application for future openings in those areas as new committees are created.

Other Interests: At this time, I would welcome the opportunity to continue learning more about our community and its needs so I can better understand where support is needed most. My goal is to align my involvement in areas where I can add the greatest value and make a meaningful impact.

## Personal Information

List your work experience: Farm Hand, Commercial Truck Driver - Primary focus was Milk for 12 Years (part-time), Engineer for Oshkosh Corporation - Defense for 11 years with an additional 7 years as the Chief Engineer for Oshkosh Corporation -McNeilus.

**List any Civic, Professional and Community Activity involvement:**

As an engineering (Bachelor of Science in Mechanical Engineering (BSME) with certifications from The University of Newcastle, Australia) my primary professional focus I participate in multiple professional communities such as ANSI, FMVSS, SAE and through my involvement have supported change and supporting stability.

**Why do you want to be a City Councilmember or on a committee, commission, task force or work as an Election Judge?**

I want to be a Mantorville City Councilmember because I care deeply about the long-term strength, character, and sustainability of our community. Mantorville has a unique identity and strong sense of community, and I want to help ensure we preserve what makes it special while planning responsibly for the future.

**What skills, strengths, or abilities do you believe you will add to the group?**

First and foremost, I want to acknowledge the tremendous impact that the prior community member(s) have done. Their years of service, dedication, and care for Mantorville set a high standard. Anyone stepping into this role does so with deep respect for the foundation they helped build.

I grew up in a small-town environment rooted in farm, family, and strong community values. That upbringing shaped my belief in showing up, helping where needed, and supporting your neighbors. Community isn't just where we live, it's who we are.

Professionally, I've had the opportunity to lead projects and work with diverse groups of people to move important initiatives forward. What that has taught me most is the importance of listening first, being thoughtful in decision-making, and focusing on long-term stewardship rather than short-term reactions.

If given the opportunity to serve, my goal would simply be to support this community with steady leadership support, transparency, and respect for the people who call Mantorville home. I am willing to do the work behind the scenes, collaborate with others, and help continue the strong legacy of service that has guided our city for so many years.

Mantorville is a special place, and I would consider it an honor to contribute in whatever way I can.

**List any additional comments:** \_\_\_\_\_

\_\_\_\_\_

\_\_\_\_\_



List any Civic, Professional and Community Activity involvement:

---

I was part of a 3-person team that organized and coordinated a bingo, silent auction, and raffle benefit for the benefit of my friend's 5-year old daughter who had been diagnosed with a rare brain cancer. The event ended up raising more than \$50,000 for her and her family.

---

Why do you want to be a City Councilmember or on a committee, commission, task force or work as an Election Judge?

---

I would like to serve on the City Council as a way to volunteer my time to help in any way I can. We moved to Mantorville about 18 months ago and have loved it. My family (wife, 8 year old daughter, and 5 year old son) and I love the community events around town along with the multiple parks and things to do for kids. I thing Mantorville is very special in that it is a very community-oriented place and I would like to ensure that we foster that growth.

---

What skills, strengths, or abilities do you believe you will add to the group?

---

As a father to a young(ish) family, I think I would provide a different perspective to that already present on the council. I have been in a leadership position at my career for 15+ years and I am not afraid of the demands the responsibility of the position would entail.

---

List any additional comments: \_\_\_\_\_

As I stated above, we just recently moved into town and have been very impressed with the amount of activities that a town of this size offers. We also really enjoy the sense of community these events bring out in everyone and I want to see this continue and grow. We plan on living in town for the long haul and I thought this might be a good way for me to give back to the community.

---

Please return this form to:

Gretchen Lohrbach, City Clerk-Treasurer  
City of Mantorville  
21 5<sup>th</sup> St E, PO Box 188  
Mantorville MN 55955  
[gretchen@mantorville.com](mailto:gretchen@mantorville.com)  
Questions, call: 507-635-5170

Revd 2/18/26  
US

# City of Mantorville Council/Committee Appointment Application Form

Date Feb. 18, 2026

## General Information

Name Schroeder Laura N  
Last First MI

Address \_\_\_\_\_  
Street City State Zip

Phone Numbers: Home \_\_\_\_\_ Work \_\_\_\_\_  
Cell \_\_\_\_\_

Email Address: \_\_\_\_\_

## Council/Committees

If you wish to be considered for more than one committee or function, please number in order of preference.

- City Council
- Election Judge
- Park Board
- Party Affiliation or  No Party  
(If applying for Election Judge)
- Economic Development Authority

## Special Interest

As the Council prioritizes its goals, it may create additional/new committees or task forces from time to time. If you have other specific areas or topics of interest, please indicate those interests and we will retain your application for future openings in those areas as new committees are created.

Other Interests: \_\_\_\_\_  
\_\_\_\_\_

## Personal Information

List your work experience: \_\_\_\_\_

- Mayo Clinic (Rochester, MN.)
- Orthopedic Research x 6 years
- Physical Therapist x 34 years
- Supervisor of Therapy Services x 14 years
- Epic-Systems - credentialed trainer x 2 years

List any Civic, Professional and Community Activity involvement:

- Mantorville Restoration Association - current member
- Dodge County United Way, Executive Board - past member
- St. Johns Lutheran Church (Kasson, MN.) past council member
- KMVB association - past founding member / past treasurer

Why do you want to be a City Councilmember or on a committee, commission, task force or work as an Election Judge?

Now that I'm retired, I have the time and energy to give back to Mantorville and my local community where my family and I have lived for 34 years. I believe that I would be an excellent steward of our community resources which includes listening →

What skills, strengths, or abilities do you believe you will add to the group?

As a physical therapist, I have worked with thousands of patients and have strong experience supervising a diverse workforce and working with other leaders at Mayo Clinic. I have a →

List any additional comments: If selected for this position, I really look forward to learning from and working with the city council members and city staff about how our local government manages resources and supports our community.

Please return this form to:

Gretchen Lohrbach, City Clerk-Treasurer  
City of Mantorville  
21 5th St E, PO Box 188  
Mantorville MN 55955  
[gretchen@mantorville.com](mailto:gretchen@mantorville.com)  
Questions, call: 507-635-5170

Thank you,  
Laura Schreeder

listening to our residents, asking questions and making fiscally responsible decisions that support current needs while keeping in mind the long-term health and vitality of our community.

---

collaborative, people-centered leadership style grounded in active listening, problem-solving and trust.

In addition, I have a MBA degree which allows me to evaluate budgets, analyze priorities, and make thoughtful, data-informed decisions while never losing sight of the human impact from these decisions.



**List any Civic, Professional and Community Activity involvement:**

I help my mom, Linda Schmidt, with many ideas and activities that she plans at the Old School Cafe

**Why do you want to be a City Councilmember or on a committee, commission, task force or work as an Election Judge?**

I've lived in Mantorville for 16 years now, and I am looking for ways to be more involved in my community. I am raising my kids here so feel it is important to be an advocate for things that impact my family.

**What skills, strengths, or abilities do you believe you will add to the group?**

Because of my long tenure at the Cafe, I have met many of our local residents and feel like I have their best interests in mind. I have an event-planning background which gives me strengths in logistics, details, and budgeting. I am also familiar with social media advertising.

**List any additional comments:**

Please return this form to:

Gretchen Lohrbach, City Clerk-Treasurer  
City of Mantorville  
21 5<sup>th</sup> St E, PO Box 188  
Mantorville MN 55955  
[gretchen@mantorville.com](mailto:gretchen@mantorville.com)  
Questions, call: 507-635-5170



List any Civic, Professional and Community Activity involvement:

*Union, UFW, Colsguard*

Why do you want to be a City Councilmember or on a committee, commission, task force or work as an Election Judge?

*I think out side the box. There is lots in the city which need new ideas used for. Which may work skill will help understand project.*

What skills, strengths, or abilities do you believe you will add to the group?

*I have all the training to be a city council member*

List any additional comments:

Please return this form to:

Gretchen Lohrbach, City Clerk-Treasurer  
City of Mantorville  
21 5<sup>th</sup> St E, PO Box 188  
Mantorville MN 55955  
[gretchen@mantorville.com](mailto:gretchen@mantorville.com)  
Questions, call: 507-635-5170



**CITY OF MANTORVILLE**

**ORDINANCE NO. 2026-01**

**AN ORDINANCE AMENDING SECTION 150.073 OF THE  
CODE OF ORDINANCES OF THE CITY OF MANTORVILLE  
REGARDING THE HISTORIC DISTRICT**

**THE CITY COUNCIL OF THE CITY OF MANTORVILLE, MINNESOTA, HEREBY  
ORDAINS:**

**Section 1.** Section 150.073 of the Mantorville City Code is hereby amended by deleting the ~~stricken~~ language and adding the double-underlined language as follows:

**§ 150.073 HISTORIC DISTRICT.**

(A) *Purpose and intent.* It is the purpose and intent of the Historic District to preserve the environmental values of the City of Mantorville and its identity derived through its established Historic District by:

- (1) Protecting against destruction of or encroachment upon historic areas, structures, and premises;
- (2) Encouraging uses, which will lead to their continuance, conservation and improvement in a manner appropriate to the preservation of the cultural, social, economic, political, and architectural heritage of the City of Mantorville;
- (3) Preventing creation of environmental influences adverse to the purposes; and
- (4) Assuring that new structures and uses within the districts will be in keeping with the character to be preserved and enhanced.

(B) *Establishment of Historic District.* The Historic District contains a set of regulations superimposed upon the existing zoning use districts, superceding existing underlying regulations only to the extent expressed in the Historic District provisions, leaving in effect, in all other respects, the regulations applicable to the underlying use district in which the land is situated. An HD postfixed to a use district code letter designates the Historic District. Within this district, all uses not allowed as permitted uses are prohibited.

(C) *Establishment of the Restoration Association.* ~~The Mantorville Restoration Association (MRA) is hereby appointed the responsibility of giving counsel to the governing body regarding the advisability of issuing a permit for construction, reconstruction, exterior alteration, razing, or relocation of any building or structure within the Historic District. For this purpose, the Mantorville Restoration Association may make and alter rules and regulations for its own organization and procedure. RESERVED.~~

(D) *Applicability.* No building or structure, including signs, shall be erected, constructed, reconstructed, substantially altered or restored, or razed within the Historic District unless the same is first approved by the governing body, acting upon the advice of ~~the Mantorville Restoration Association~~ any a duly established city heritage preservation commission formed under Minnesota Statutes, section 471.193, if one exists, and making a finding that the proposal is architecturally compatible with the historical and/or architectural aspects of the area. If any proposed construction, reconstruction, exterior alteration, or relocation of a building would otherwise require the approval of a variance in accordance with the procedures set forth in § 150.111, the City Engineer shall notify the governing body of the facts and at the next regularly scheduled meeting, the governing body shall have the power, in its discretion, to waive any standards required by this Zoning Ordinance and to grant approval without the necessity of the applicant obtaining a variance as required by § 150.111. Before granting the approval, and waiver, the governing body shall make a finding that the waiver is deemed necessary in furtherance of the purpose and intent of the Historic District.

(E) *Standard for review.* ~~The Restoration Association and~~ governing body and city heritage preservation commission, if applicable, shall consider the following in review and action upon any proposal subject to the provisions of this section.

(1) Exterior architectural features including all signs, which are subject to public view from a public street or public place.

(2) General design, arrangement, texture, material, color, and fenestration of the proposed building or structure and the relation of the factors to similar features of buildings or structures of the period between 1854 and 1900.

(3) The extent to which the building or structure would be architecturally harmonious or compatible with the period between 1854 and 1900.

(4) The extent to which the building or structure will promote the general welfare of the city and all citizens by the preservation and protection of historic places and areas of historic interest in the city.

(5) The extent to which the preservation and protection will promote the general welfare by maintaining and increasing real estate values; generating business, attracting tourists, students, writers, historians, artists, and artisans; attracting new residents; encouraging study and interest in American history; stimulating interest and study in architecture and design; educating citizens in American culture and heritage; and making the city a more attractive and desirable place in which to live.

(6) ~~The Restoration Association or~~ governing body and city heritage preservation commission, if applicable, shall not consider interior arrangement, relative size of the building or structure, detailed design or features not subject to any public view, and shall not make any requirements except for the purpose of preventing developments architecturally incompatible

with the historic aspects of the Historic District.

**Section 2.** For avoidance of doubt, the intent of this ordinance is to formally terminate the City of Mantorville’s reliance on the Mantorville Restoration Association as an advisory body to the City Council with respect to buildings and structures within the Historic District. Accordingly, following the effective date of this ordinance, the Mantorville Restoration Association will no longer serve in that capacity. Furthermore, all new references above to a duly formed city heritage preservation commission shall only apply if and when such a commission is formally established by the Mantorville City Council pursuant to Minnesota Statutes, section 471.193.

**Section 3.** This ordinance shall be in full force and effect upon its passage and publication.

Passed by the City Council of the City of Mantorville, Minnesota, this 9<sup>th</sup> day of March, 2026.

---

Jeffrey Ingalls, Mayor

ATTEST:

---

Gretchen Lohrbach, City Clerk Treasurer

**CITY OF MANTORVILLE**

**RESOLUTION NO. 2026-07**

**RESOLUTION AUTHORIZING PUBLICATION OF  
ORDINANCE NO. 2026-01 BY TITLE AND SUMMARY**

**WHEREAS**, the city council of the City of Mantorville has adopted Ordinance No. 2026-01, An Ordinance Amending Section 150.073 of the Code of Ordinances of the City of Mantorville Regarding the Historic District; and

**WHEREAS**, Minnesota Statutes § 412.191, subdivision 4 allows publication by title and summary in the case of lengthy ordinances or those containing charts or maps; and

**WHEREAS**, the city council believes that the following summary would clearly inform the public of the intent and effect of the ordinance.

**NOW, THEREFORE, BE IT RESOLVED** by the city council of the City of Mantorville that city staff shall cause the following summary of Ordinance No. 2026-01 to be published in the official newspaper in lieu of the ordinance in its entirety:

**Public Notice**

The city council of the City of Mantorville has adopted Ordinance No. 2026-01, An Ordinance Amending Section 150.073 of the Code of Ordinances of the City of Mantorville Regarding the Historic District. The ordinance removes from the city code all references to the Mantorville Restoration Association. The intent of the ordinance is to formally terminate the City of Mantorville’s reliance on the Mantorville Restoration Association as an advisory body to the city council with respect to buildings and structures within the City’s Historic District. Furthermore, references to a not-yet formed city heritage preservation commission were added and shall become relevant if and when such a commission is formally established by the Mantorville City Council pursuant to Minnesota Statutes, section 471.193. The full text of the ordinance is available at city hall during regular business hours.

**BE IT FURTHER RESOLVED** by the city council of the City of Mantorville that city staff keep a copy of the ordinance in their office at city hall for public inspection and that they post a full copy of the ordinance in a public place within the city.

Dated: March 9, 2026.

**BY THE CITY COUNCIL**

\_\_\_\_\_  
Jeffrey Ingalls, Mayor

**ATTEST:**

\_\_\_\_\_  
Gretchen Lohrbach, City Clerk Treasurer

**CITY OF MANTORVILLE**

**ORDINANCE No. 2026-02**

**AN ORDINANCE UPDATING THE CITY OF MANTORVILLE' MASTER FEE SCHEDULE**

THE CITY COUNCIL OF THE CITY OF MANTORVILLE, MINNESOTA HEREBY ORDAINS:

**Section 1.** The City of Mantorville's Master Fee Schedule, which was adopted pursuant to Mantorville City Code, Section 32.02 and is contained in Appendix A to the Mantorville City Code, is hereby amended by replacing it in its entirety with the attached Exhibit A, entitled "2026 Master Fee Schedule for the City Of Mantorville."

**Section 2.** In accordance with Minnesota Statutes, section 412.191, subd. 4, because publication of this ordinance by title and summary would clearly inform the public of its intent and effect, City staff shall have only the following summary printed in the official City newspaper in lieu of the complete ordinance:

On March 9, 2026, the Mantorville City Council adopted Ordinance 2026-02, An Ordinance Updating the City's Master Fee Schedule, which approved the City's revised master fee schedule. Said ordinance established new fees for open records/public information requests, MDH fees set by the State of Minnesota, food trucks, fire department billing rates, and camping fees. All other fees were unchanged. A printed copy of the ordinance, which includes the new master fee schedule, is available for inspection by any person during regular office hours at the office of the city clerk-treasurer.

**Section 3.** This ordinance shall be in full force and effect upon its passage and publication. Staff shall keep a copy of the ordinance in the clerk's office at city hall for public inspection and post a full copy of the ordinance in a public place within the city.

Approved by the Mantorville City Council this 9<sup>th</sup> day of March, 2026.

---

Mayor, Jeffrey Ingalls

ATTEST:

---

City Clerk Treasurer, Gretchen Lohrbach

**EXHIBIT A**  
**CITY OF MANTORVILLE**  
**2026 MASTER FEE SCHEDULE FOR THE CITY OF MANTORVILLE**

Fees shall be hereby established. In the event of a conflict, this Fee Schedule shall prevail:

**ADMINISTRATIVE FEES:**

Copies	25¢ per page black and white; (10¢ if paper furnished) 50¢ double-sided \$1.00 per page, color
NSF/Closed Account/Stop Payment	\$30.00 per check
Copy of Council Meeting recording (disk)	\$5.00 per disk or flash drive
Duplicate License/Permit (any type)	\$10.00
Mileage Reimbursement	@ IRS allowed rate
Maps – 10 inch x 17 inch size	\$1.00 black and white \$2.00 color
Copy of City Code	\$100.00 – Non-binder, double sided
Affidavit of Candidacy Filing Fee	\$2.00
Open Records/Public Information Request	<del>\$22.00 per hour</del> \$23.50 per hour
Document Recording	\$50.00
Mowing/Yard Cleanup/Other	\$100 per hour with a 1 hour minimum
Over 60 Days late fee for Fire Dept. Calls	\$25.00

**BUILDING PERMIT FEES:**

Administrative Fee	\$75.00
Plan Review Application Fee	\$150.00 *Applied toward Plan Review Fee if Permit is issued
Plan Review Fee	65% of building permit fee
Valued Permit Fees	
\$1-\$999	\$55.00
\$1,000-\$4,999	\$55+\$20/\$1,000 for each \$1,000>\$1,000
\$5,000-\$19,999	\$121+\$6/\$1,000 for each \$1,000>\$5,000
\$20,000-\$99,999	\$216+\$5/\$10,00 for each \$1,000>\$20,000
\$100,00-\$249,999	\$614.75+\$3.75/\$1,000 for each \$1,000>\$100,000
\$250,000-\$499,999	\$1,176.75+\$3.65/\$1,000 for each \$1,000>\$250,000

\$500,000-\$749,999	\$2,088.50+\$3.50/\$1,000 for each \$1,000>\$500,000
\$750,000-\$999,999	\$2,962.25+\$3.25/\$1,000 for each \$1,000>\$750,000
\$1,000,000-\$1,999,999	\$3,774.50+\$3.20/\$1,000 for each \$1,000>\$1,000,000
\$2,000,000-\$4,999,999	\$6,950.75+\$2.25/\$1,000 for each \$1,000>\$2,000,000
\$5,000,000-\$9,999,999	\$13,695.75+\$2.20/\$1,000 for each \$1,000>\$5,000,000
\$10,000,000 and over	\$24,695.75+\$2.20/\$1,000 for each \$1,000>\$10,000,000
Commercial Re-shingle	Contact CMS to determine if flat fee
Flat Fee Permits: Reroof/side, repair or replace fixture/appliance, windows/doors. Egress Windows NOT FLAT FEE	\$127.00 (fee is ½, \$63.50 if only 1 item maintained per permit)
Manufactured Home	\$220.00
Demolition	\$175.00
All Others	\$100.00
Reinspection Fee (if special trip needed)	\$80.00
Mechanical Permit	\$35.00
Plumbing Permit	\$35.00
State Surcharge Fees Per Minnesota Statute 326B.148	
\$0-\$1,000,000	\$5/\$10,000 for each value up to \$1,000,000
\$1,000,001-\$2,000,000	\$500+\$4/\$10,000 for each value between \$1,000,001 & \$2,000,000
\$2,000,001-\$3,000,000	\$900+\$3/\$10,000 for each value between \$2,000,001 & \$3,000,000
\$3,000,001-\$4,000,000	\$1,200+\$2/\$10,000 for each value between \$3,000,001 & \$4,000,000
\$4,000,001-\$5,000,000	\$1,400+\$1/\$10,000 for each value between \$400,001 & \$5,000,000
Greater than \$5,000,000	\$1,500 +\$0.50/\$10,000 for each value exceeding \$5,000,001
Reissue of Expired Permit	Equal to original permit fee

Failure to Obtain Building Permit	\$150.00 or a sum equal to two times the building permit fee applicable to the project, whichever is greater
Print/Copy plans submitted electronically 11x17 or smaller	\$0.25 per page
Print/Copy large plans (plat size) submitted electronically	\$5 per page

**LAND USE FEES:**

An additional fee of up to two (2) hours of consultant time may be added to land use applications. See specific application for consultant costs. Consultant time beyond two (2) hours will be discussed with the Applicant prior to the City proceeding with the application.	
Preliminary Plat	\$350.00 + \$1.00/lot + all associated costs
Final Plat	\$300.00 + all associated costs
Minor Subdivision	\$300.00 (less than 3 lots) + all associated costs
Variance	\$300.00
Rezone	\$400.00
Conditional Use Permit	\$300.00
Parkland Dedication	\$100.00 per lot
Annexation	\$450.00 + all associated costs
Appeal	\$150.00
Metes & Bounds Lot Split	\$300.00 + all associated costs

<b>UTILITIES:</b>	
Water/Sewer Accessibility Charge to Developers	
Water (WAC)	\$2,000.00 per developable acre
Sewer (SAC)	\$2,000.00 per developable acre
Connection Fee for Residential and Commercial Construction	
Water	\$1000.00 per building
Sewer	\$2,639.00 per building
Residential and Commercial Utility Base Rates and Charges Per Gallon are set annually by the Mantorville City Council. These charges are published on the City webpage and in the local newspaper.	
Water Shut Off/Reconnection	\$100.00
<b>**Residents that leave for the winter months and request their water to be shut-off at the curb will be charged the \$100 fee when the water is turned back on. Monthly Base fees are not charged when the water is shut off at the curb.</b>	
STORM WATER	

Residential – Less than 2 Acres	\$4.00 per month
Residential – More than 2 Acres	\$5.00 per month
Non-Residential	\$16.00 per acre with a \$6.00 minimum charge
Sump Pump Violations	\$100.00 per day of non-compliance
FAILURE TO INSTALL A WATER METER	\$50.00 per month, in addition to regular utility charges
Outside Water Meter/Meter Replace	\$430.00
MDH Fee (set by State)	<del>\$.81 per month</del> \$1.28 per month
UB Late Fee	20% of outstanding current month bill
Bulk Water Rate	\$10.00 per thousand gallons + Water Base Fee

**LICENSE & PERMIT FEES:**

Alcoholic Beverages – Set by State Statute	
3.2% Malt Liquor On Sale	\$200.00
3.2% Malt Liquor Off Sale	\$100.00
Consumption & Display	\$250.00 (check made out to State of Minnesota)
Intoxicating On Sale	\$2,500.00
Intoxicating Off Sale	\$100.00
Club On Sale	\$100.00
Sunday Intoxicating On Sale	\$200.00
Wine On Sale	\$500.00
Investigation	Associated Costs
Temporary Liquor	\$25.00 per day
Mechanical Amusement Devices	\$50.00 (1-4 devices); \$15.00 each additional
Dog License	
Lifetime License	\$25.00
Replacement Tag	\$5.00
Dog Impound Fees 2024	\$100 plus cost of impound
Kennel License	\$150.00: per renewal; bi-annually
Chicken Permit	\$25.00; per renewal, annually
Garbage Haulers Permit	\$500.00 annually
Fireworks Display	\$25.00 each show
Peddlers/Solicitor	\$10.00 per day, per applicant
Background Investigation	\$100.00

Food Trucks	<del>\$25.00; per renewal, annually \$100.00 for a 6 month permit and \$250.00 for a year-long permit</del>
Excavation Permit (right-of-way)	\$50.00
Water/Sewer Contractor Permit	\$50.00 (Contractor's License to do work)
Bond Amount	\$25,000.00 (copy of State required bond)
Park Shelter Reservation	\$40.00 per day
Bandshell Reservation	\$50.00 per day / \$100 refundable deposit
Permanent Sign Permit	\$50.00 + any required Building Permit
Rental Property License	\$25.00 each dwelling containing less than 4 units; \$30.00 each dwelling for 4 to 8 units; \$3.50 per day (up to 20 days) for failure to renew license
Golf Cart Permit	\$5.00

**MANTORVILLE FIRE DEPARTMENT  
2023 BILLING RATES**

	Cost
<b>Fire (e.g., Structure, Grass, Vehicle, etc.) – First two hours</b>	<del>\$750.00</del> <b>\$850.00</b>
<b>Hours beyond first two hours</b>	<del>\$250.00</del> <b>\$300.00 per hour</b>
<b>Incident where major equipment and manpower used</b>	<del>\$750.00</del> <b>\$850.00</b>
<b>Hours beyond first two hours</b>	<del>\$250.00</del> <b>\$300.00 per hour</b>
<b>Request for Assistance (minimal or no equipment used)</b>	<b>\$250.00 per hour</b>
<b>Request for Assistance (cancelled before arrival)</b>	<b>NO CHARGE</b>
<b>Alarm Investigation (e.g., carbon monoxide, smoke/odor)</b>	<b>\$500.00</b>
<b>False House Alarm System Triggered (investigate)</b>	<b>\$500.00</b>
<b>False House Alarm System Triggered (cancelled before arrival)</b>	<b>NO CHARGE</b>
<b>Hazardous Material Spill (e.g., fuel spill, etc.)</b>	<del>\$500.00</del> <b>Fire Call fee + expenses</b>
<b>Motor Vehicle Accident (per vehicle involved)</b>	<del>\$750.00</del> <b>\$800.00</b>
<b>First Responder Only Request</b>	<b>NO CHARGE</b>
<b>Charge for Foam</b>	<b>\$250.00 per 5 gallons</b>

**Direct Expense Additions  
Mutual Aid Bills from Other Fire Departments  
(typically fuel and foam)**

**Mutual Aid Provided to Other Departments --- cost of fuel and foam**

**Travel time is not included in any billing hours.**

**2023 CAMPSITE FEE SCHEDULE  
WATER – SEWER – ELECTRIC  
SITES 1 – 10**

**All fees listed include required State tax**

1 NIGHT	<del>\$30.00</del> \$32.00
2 NIGHTS	<del>\$60.00</del> \$64.00
3 NIGHTS	<del>\$90.00</del> \$96.00
4 NIGHTS	<del>\$120.00</del> \$128.00
5 NIGHTS	<del>\$150.00</del> \$160.00
6 NIGHTS	<del>\$180.00</del> \$192.00
WEEKLY	<del>\$210.00</del> \$224.00
MONTHLY	<del>\$840.00</del> \$896.00

The Campground took in approximately \$26,800 last year.  
Expenses last year were approximately \$18,000.  
A 5% increase in campground expenses is approximately \$900.  
Increasing by \$2 per night will generate an additional revenue of \$1,700.

Campground averages \$10,000 in income over last few years.

**CITY OF MANTORVILLE**  
**APPLICATION FOR PLATTED LOT-SPLIT/LOT COMBINATION**

Fee \$300.00

(A) Applicant's Name Richard Balcome Phone \_\_\_\_\_

(B) Address 620 6th St W Mantorville Mn 55955

(C) Legal Description of Property Section 17-Twp 107 Range 016 Mantors add.  
Lots 7 thru 10 Block 21 & Vacated Madison St plot 25426

(D) Property Owner's Name (if different from above) \_\_\_\_\_  
Address \_\_\_\_\_ Phone \_\_\_\_\_

(E) Description of Request Lot split

(F) Reason(s) for Request Build new house

(G) Present Zoning Classification \_\_\_\_\_

(H) Existing Use of Property Res Homestead

A certified certificate of survey showing the new lot split or lot combination is required to be attached as part of this application. No application will be processed without the required information.

The undersigned certifies that they are familiar with application fees and other associated costs (City Attorney fees, Consultant fees, and recording fees) that must be paid before Council can grant approval, and also with the procedural requirements of the Mantorville Zoning Ordinance and other applicable City ordinances. Submittal of the application, required information and fee does not guarantee approval. Additional information may be needed or conditions may exist that would prevent approval.

  
Applicants Signature

01/09/2026  
Date

\_\_\_\_\_  
Applicants Signature

\_\_\_\_\_  
Date

\_\_\_\_\_  
Applicants Signature

\_\_\_\_\_  
Date

**FOR OFFICE USE ONLY**

Date Submitted 1/9/26

Date Accepted 3/6/26 Fee Paid 300,00

Public Hearing Date: NA

(Circle one) Approved Denied by the City Council on \_\_\_\_\_, \_\_\_\_\_.

If approved, the following conditions were prescribed:

- 1. \_\_\_\_\_
- 2. \_\_\_\_\_
- 3. \_\_\_\_\_
- 4. \_\_\_\_\_

If denied, denial was for the following reason(s): \_\_\_\_\_

**PROCEDURES:** The procedure for obtaining approval for a lot combination or lot split are as follows:

- 1. The property owner or his agent shall file the completed application together with the required exhibits and pay a filing fee as established by the City Council.
- 2. When the City Clerk determines the application to be complete the public hearing date will be set.
- 3. The City Clerk shall publish a notice of the Public Hearing at least once in the legal newspaper not less than ten (10) days prior to the hearing.
- 4. The City Clerk shall give written notice to all property owners within 350 feet of the outer boundaries of the property in question; however, failure of any property owner to receive such notification shall not invalidate the proceedings.
- 5. The City Council shall take action to approve or deny the application within sixty (60) days of receiving a completed application. If the Council cannot take action to approve or deny the application within these sixty (60) days, the Council may extend the timeline for taking action before the end of the initial 60-day period by providing written notice of the extension to the applicant. The notification shall state the reasons for the extension and its anticipated length, which may not exceed sixty(60) days unless approved by the applicant in writing.
- 8. The City Council shall act upon the application within thirty (30) days after the Public Hearing.
- 9. No application shall be considered by the City Council within a one (1) year period following a denial of such request, except that the City Clerk may permit a new application to be filed if new evidence or a change in circumstances warrant it.

**REQUIRED EXHIBITS FOR LOT SPLIT OR LOT COMBINATION**

- Yes \_\_\_ No 1. A completed application form and fee
- Yes \_\_\_ No 2. A certified survey of the property will be required. The survey must show all buildings and permanent structures on the property.
- Yes \_\_\_ No 3. Evidence of ownership or enforceable option on the property

**NOTE: SUBMITTAL OF THE REQUIRED INFORMATION DOES NOT GUARANTEE THE ISSUANCE OF A VARIANCE. ADDITIONAL INFORMATION MAY BE NEEDED OR CONDITIONS MAY EXIST THAT WOULD PREVENT THE ACTUAL GRANTING OF A VARIANCE.**

**CITY OF MANTORVILLE  
CHECKLIST  
MINOR LOT SPLIT/METES & BOUNDS/LOT COMBINATION**

APPLICANT: Richard Balcome PID# 25.426.1660

Date Application considered complete 3/6/26. 60 Day Rule begins

The following is a checklist that should be included in the file for every Lot Split of a Platted City Lot before it is place on permanent file.

**PERMIT APPLICATION:** Submitted On: 1/9/26

**CERTIFICATE OF SURVEY** Submitted On: 3/6/26

**AFFIDAVIT OF PUBLICATION:** Published On: NA

The original Affidavit of Publication for the Public Hearing should be kept with the file. The publication must occur at lest ten (10) days in advance of the hearing.

**AFFIDAVIT OF MAILING:** Mailed On: NA

The original Affidavit of Mailing for the Public hearing should be kept with the file. This affidavit should include a copy of the notice sent to the property owners, a list of all parties sent a notice and the signature of the staff person principally responsible for mailing the notice. The notice must be mailed to adjacent property owners within 350 feet at least ten (10) days in advance of the hearing. However, failure to notify any adjoining property owners will not negate the public hearing process.

**RETURNED NOTICES:** If any of the mailed notices are returned for any reason, these mail pieces should be kept in the file.

**FINDINGS OF FACT:** Public Hearing Held On: NA

The "findings of fact" for approving or denying the application must be included in the file, and should be included in the resolution itself, if there is one.

**RESOLUTION OR MINUTES APPROVING/DENYING REQUEST:**  
Approved On: \_\_\_\_\_

If a resolution is not utilized, an excerpt of the minutes or other certified copy of the minutes of the City Council meeting should be placed in the file.

**NOTICE OF APPROVAL:** Recorded On: \_\_\_\_\_

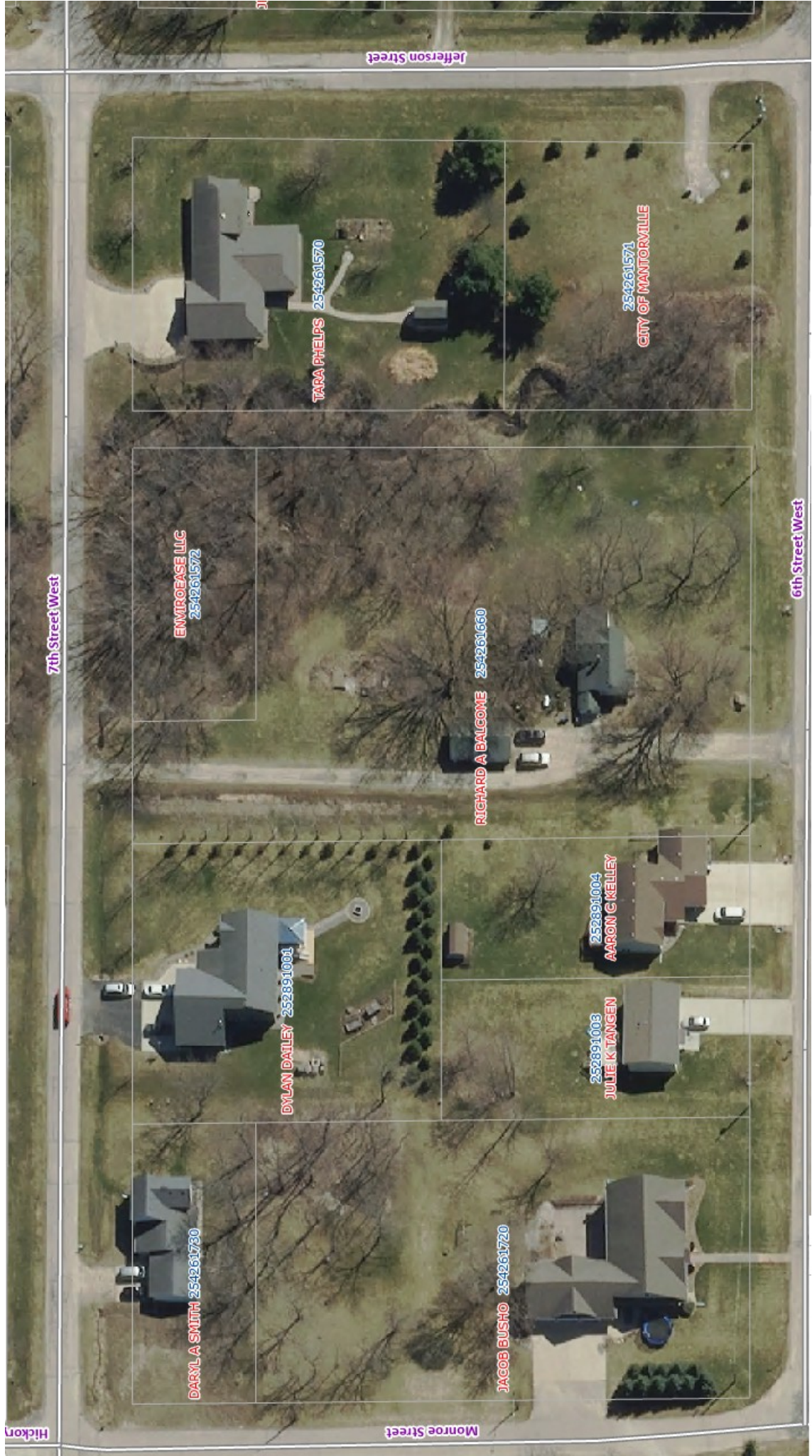

Hickory

DARYL A SMITH 254261730

DYLAN DAILEY 252891001

EMVIOEASE LLC  
254261572

TARA PHELPS 254261570

JACOB BUSHO 254261720

RICHARD A BALCOMBE 254261660

252891008  
JULIE K TANGEN

252891004  
AARON C KELLEY

254261571  
CITY OF MANTORVILLE

Jefferson Street

7th Street West

6th Street West

Monroe Street

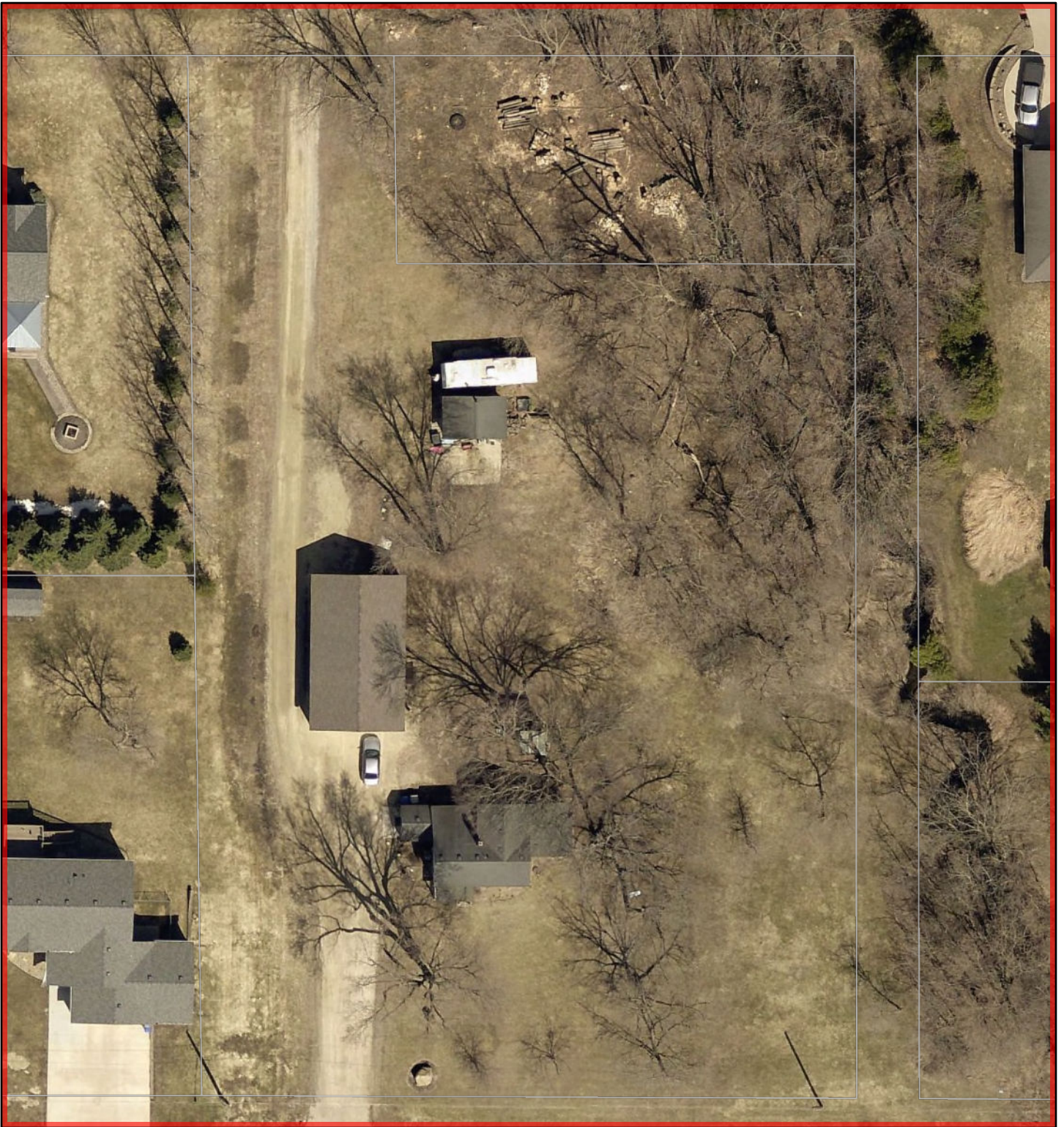

# ArcGIS WebMap

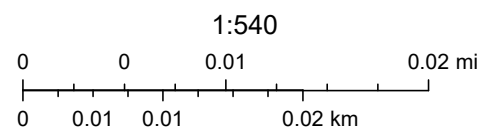

November 5, 2025

 Parcels

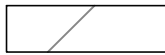

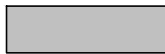
-  RICHARD BALCOMBE RESIDUE AREA
-  = CONCRETE
-  = PROPOSED ACCESS EASEMENT

# CERTIFICATE OF SURVEY

## LOT 7 & PART OF LOT 8, BLOCK 21 & PART OF VACATED MADISON ST.

### FRANK MANTOR'S ADDITION DODGE COUNTY, MINNESOTA

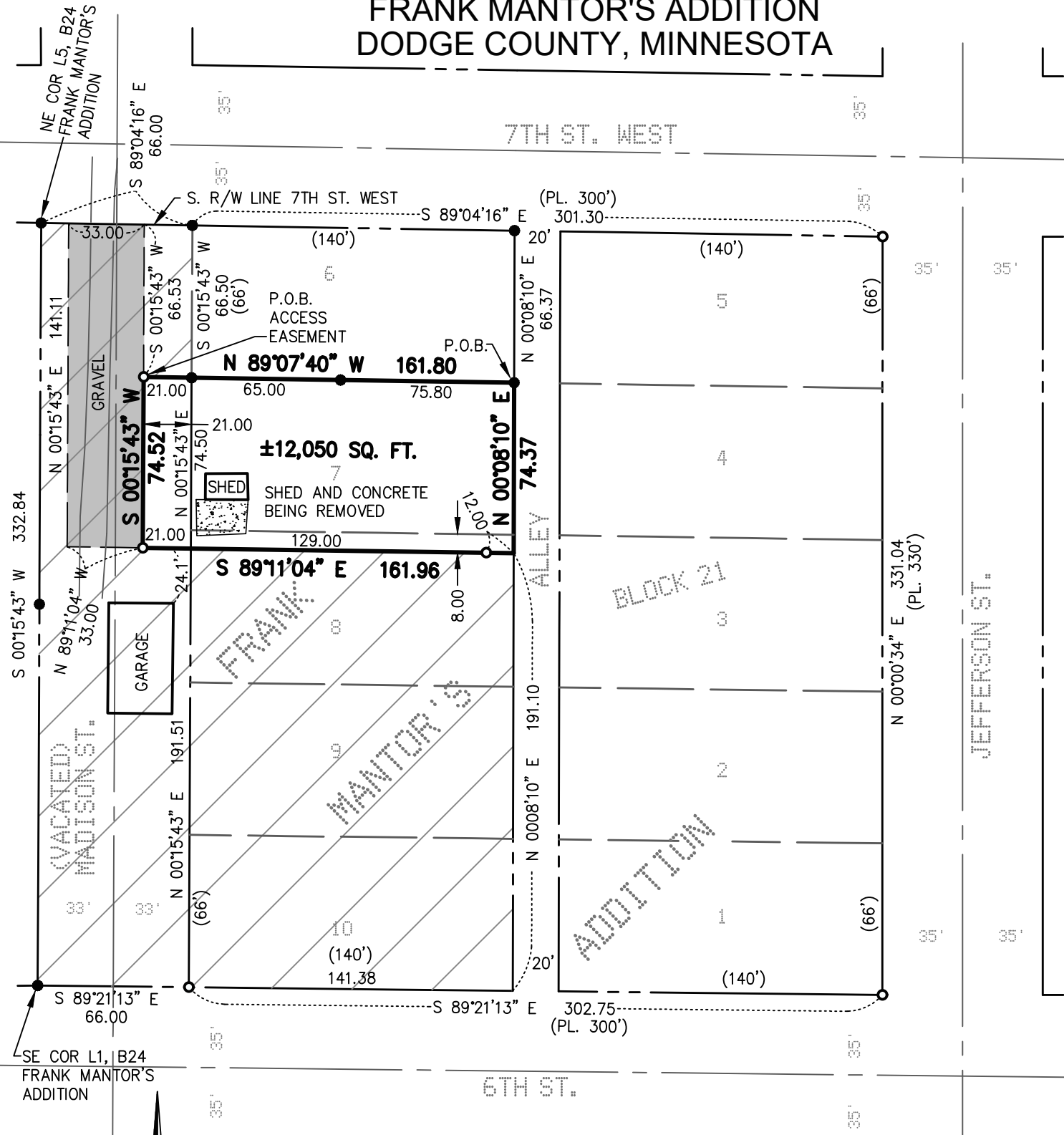

#### BASIS OF BEARINGS

All Bearings are in relationship with the Dodge County Coordinate System NAD 83, Adjusted 1996.

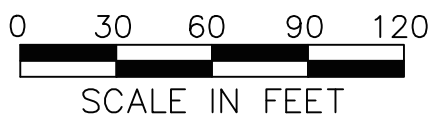

#### SURVEYOR'S NOTE

This survey is not intended to show all improvements on the property. Only those improvements observed near the boundaries that could affect boundary relationships are shown hereon.

#### PROPERTY LOCATION MAP

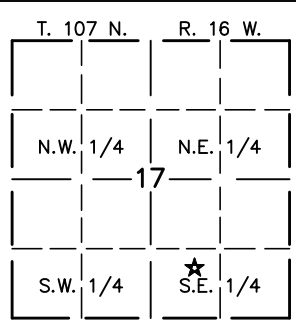

## WSE + MASSEY

**ENGINEERING & LAND SURVEYING Ltd.**  
P.O. BOX 100, KASSON, MN 55944  
PH. NO. 507-634-4505, EMAIL SURVEY@WSE.ENGINEERING

I hereby certify that this survey, plan, or report was prepared by me or under my direct supervision and that I am a duly Licensed Land Surveyor under the laws of the State of Minnesota.

RWZ

Reinhold W. Zieman

Date 3/5/2026  
LIC. NO.: 59823

THIS SURVEY AND DRAWING WAS PREPARED FOR THE EXCLUSIVE USE OF:

RICHARD BALCOMBE  
MANTORVILLE, MN

- MONUMENTS**
- FOUND (5/8" PIPE UNLESS NOTED OTHERWISE)
  - SET (5/8" PIPE UNLESS NOTED OTHERWISE)

DATE: 3/5/2026  
DWG NO. 5298SC02 JOB NO. 5298  
DRAWN BY: R.A.B. SHEET 1 OF 3

# CERTIFICATE OF SURVEY

## LOT 7 & PART OF LOT 8, BLOCK 21 & PART OF VACATED MADISON ST.

### FRANK MANTOR'S ADDITION DODGE COUNTY, MINNESOTA

DESCRIPTION

Lot 7 and that part of Lot 8, Block 21 and that part of vacated Madison Street, FRANK MANTOR'S ADDITION described as follows:

BEGINNING at the northeast corner of Lot 7 of said Block 21; thence North 89 degrees 07 minutes 40 seconds West (NOTE: All bearings are in relationship with the Dodge County Coordinate System NAD '86, Adjusted 1996), along the north line and the westerly extension of said Lot 7, a distance of 161.80 feet; thence South 00 degrees 15 minutes 43 seconds West, 74.52 feet to the westerly extension of the south line of the North 8.00 feet of Lot 8; thence South 89 degrees 11 minutes 04 seconds East, along the westerly extension and the south line of the North 8 feet of Lot 8, a distance of 161.96 feet to the east line of said Lot 8; thence North 00 degrees 08 minutes 10 seconds East, along the east line of said Lot 8 and Lot 7, a distance of 74.37 feet to the northeast corner of said Lot 7 and the POINT OF BEGINNING.

TOGETHER WITH:

An access easement, over and across that part of vacated Madison Street as platted in FRANK MANTOR'S ADDITION lying west of Block 21, described as follows:

Commencing at the northeast corner of Lot 7 of said Block 21; thence North 89 degrees 07 minutes 40 seconds West (NOTE: All bearings are in relationship with the Dodge County Coordinate System NAD '86, Adjusted 1996), along the north line and the westerly extension of said Lot 7, a distance of 161.80 feet to the POINT OF BEGINNING of said access easement; thence South 00 degrees 15 minutes 43 seconds West, 74.52 feet to the westerly extension of the south line of the North 8.00 feet of Lot 8; thence North 89 degrees 11 minutes 04 seconds West, along said westerly extension, 33.00 feet; thence North 00 degrees 15 minutes 43 seconds East, parallel with the west line of said Block 21, a distance of 141.11 feet to the south line of 7th Street West; thence South 89 degrees 04 minutes 16 seconds East, along said south line of 7th Street West, 33.00 feet; thence South 00 degrees 15 minutes 43 seconds East, along the west line of said Block 21, a distance of 66.53 to the POINT OF BEGINNING.

PROPERTY LOCATION MAP

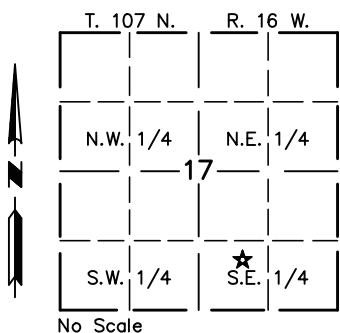

## WSE + MASSEY

**ENGINEERING & LAND SURVEYING Ltd.**

P.O. BOX 100, KASSON, MN 55944  
PH. NO. 507-634-4505, EMAIL SURVEY@WSE.ENGINEERING

I hereby certify that this survey, plan, or report was prepared by me or under my direct supervision and that I am a duly Licensed Land Surveyor under the laws of the State of Minnesota.

Date \_\_\_\_\_

\_\_\_\_\_  
Reinhold W. Zieman LIC. NO.: **59823**

THIS SURVEY AND DRAWING WAS PREPARED FOR THE EXCLUSIVE USE OF:

RICHARD BALCOME  
MANTORVILLE, MN

MONUMENTS

- FOUND (5/8" PIPE UNLESS NOTED OTHERWISE)
- SET (5/8" PIPE UNLESS NOTED OTHERWISE)

DATE: 3/5/2026

DWG NO. 5298SC02 JOB NO. 5298

DRAWN BY:    R.A.B.    SHEET 2 OF 3

# CERTIFICATE OF SURVEY

## LOT 7 & PART OF LOT 8, BLOCK 21 & PART OF VACATED MADISON ST.

### FRANK MANTOR'S ADDITION DODGE COUNTY, MINNESOTA

**Disclaimer:**

This legal description is provided for informational and reference purposes only. No field survey has been conducted for the entirety of the parent parcel. As such, the Surveyor assumes no responsibility or liability for the accuracy, completeness, or legal sufficiency of the description pertaining to the residue parcel.

#### RESIDUE DESCRIPTION

Lots 7, 8, 9, and 10, Block 21, All in Frank Mantor's Addition to the Village. now City of Mantorville and that part of vacated Madison Street in Frank Mantor's Addition to the City of Mantorville, Dodge County, Minnesota described as follows:

Beginning at the Northeast corner of Lot 5, in said Block 24; thence South to the Southeast corner of Lot 1, in said Block 24; thence East to the Southwest corner of Lot 10 in Block 21; thence North to the Northwest corner of Lot 6 in said Block 21; thence West to the Northeast corner of said Lot 5 in Block 24 the point of beginning.

together with all hereditaments and appurtenances belonging thereto. subject to the following exceptions:

Subject to covenants, easements and restrictions of record.

**EXCEPT:**

Lot 7 and that part of Lot 8, Block 21 and that part of vacated Madison Street, FRANK MANTOR'S ADDITION described as follows:

BEGINNING at the northeast corner of Lot 7 of said Block 21; thence North 89 degrees 07 minutes 40 seconds West (NOTE: All bearings are in relationship with the Dodge County Coordinate System NAD '86, Adjusted 1996), along the north line and the westerly extension of said Lot 7, a distance of 161.80 feet; thence South 00 degrees 15 minutes 43 seconds West, 74.52 feet to the westerly extension of the south line of the North 8.00 feet of Lot 8; thence South 89 degrees 11 minutes 04 seconds East, along the westerly extension and the south line of the North 8 feet of Lot 8, a distance of 161.96 feet to the east line of said Lot 8; thence North 00 degrees 08 minutes 10 seconds East, along the east line of said Lot 8 and Lot 7, a distance of 74.37 feet to the northeast corner of said Lot 7 and the POINT OF BEGINNING.

PROPERTY LOCATION MAP

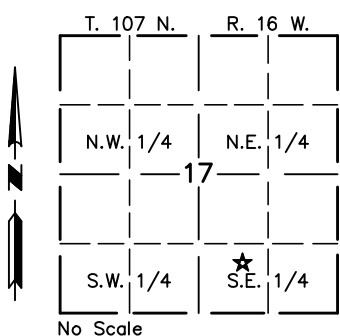

## **WSE MASSEY**

**ENGINEERING & LAND SURVEYING<sup>ltd.</sup>**

P.O. BOX 100, KASSON, MN 55944  
PH. NO. 507-634-4505, EMAIL SURVEY@WSE.ENGINEERING

**I hereby certify that this survey, plan, or report was prepared by me or under my direct supervision and that I am a duly Licensed Land Surveyor under the laws of the State of Minnesota.**

Date \_\_\_\_\_

\_\_\_\_\_  
**Reinhold W. Zieman** LIC. NO.: **59823**

THIS SURVEY AND DRAWING WAS PREPARED FOR THE EXCLUSIVE USE OF:

RICHARD BALCOME  
MANTORVILLE, MN

- MONUMENTS
- FOUND (5/8" PIPE UNLESS NOTED OTHERWISE)
  - SET (5/8" PIPE UNLESS NOTED OTHERWISE)

DATE: 3/5/2026

DWG NO. 5298SC02 JOB NO. 5298

DRAWN BY: R.A.B. SHEET 3 OF 3



# HANDEVIDT'S FIRST SUBDIVISION

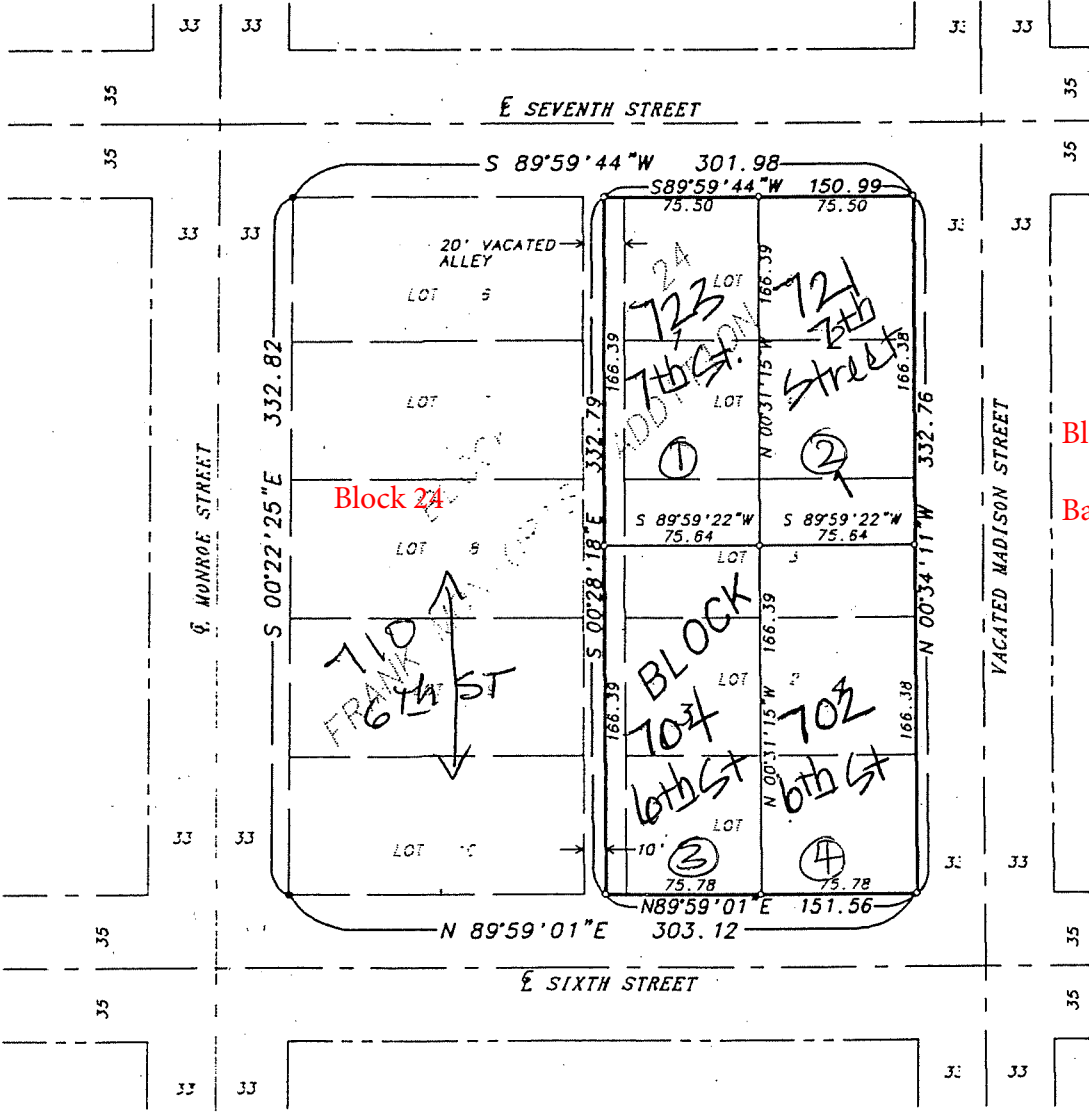
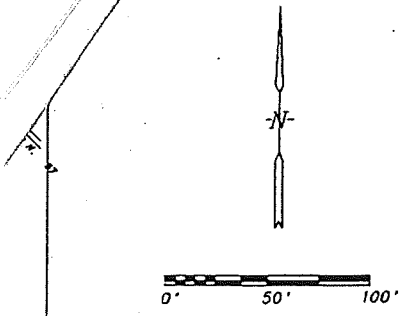

and the property  
DIVISION; that this is  
distances are  
hs of a foot; that  
ground as shown; that  
ited on the plat and  
o be designated other

orn to before me a  
, 20, by

isota approved this

isurer

e herein before  
int taxes and transfer

atically and approved

KNOW ALL  
Handevidt  
described  
Minnesota

All of Lc  
Mantorvil

Have caus  
SUBDIVISI  
public us  
and utili

In witness  
and wife,

Bradley T

Block 21

State of  
County of

Balcome

The fores  
of  
Handevidt

Dodge Cou

My commis

Documen

I here

County

Book

County

Dodge

Monuments shown thus: o are set 1/2" pipes with  
plastic cap bearing license no. 14888

Monuments shown thus: • are found monuments as  
indicated.

All bearings are in relation to the east line of Block 24, Frank  
Mantor's Addition, Mantorville, Minnesota which has an assumed  
bearing of N00°34'11"W.

Utility easement defined: An unobstructed easement for the  
construction and maintenance of all necessary overhead,  
underground, or surface public utilities including the rights to  
conduct drainage and trimming on said easement.

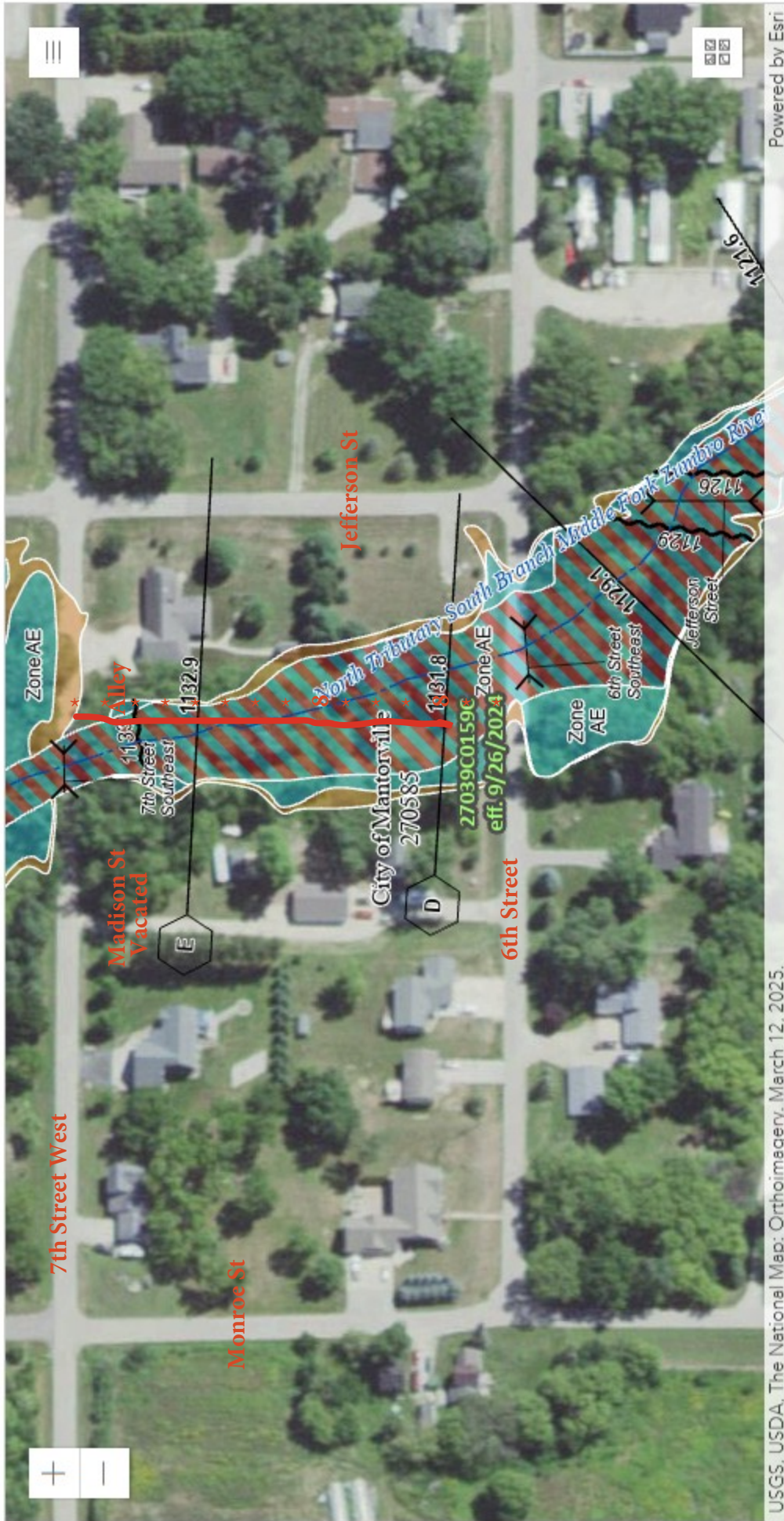

USGS, USDA, The National Map: Orthoimagery, March 12, 2025.

Powered by Esri

**PIN**

- Approximate location based on user input and does not represent an authoritative property location

**MAP PANELS**

- Selected Floodmap Boundary
- Digital Data Available
- No Digital Data Available
- Unmapped
- Area of Minimal Flood Hazard Zone X
- Effective LOMRS
- Area of Undetermined Flood Hazard Zone D
- Otherwise Protected Area
- Coastal Barrier Resources System Area

**OTHER AREAS OF FLOOD HAZARD**

- Without Base Flood Elevation (BFE) Zone A, V, ADP
- With BFE or Depth Regulatory Floodway Zone AE, AD, AH, VE, AR
- 0.2% Annual Chance Flood Hazard, Areas of 1% annual chance flood with average depth less than one foot or with drainage areas of less than one square mile Zone X
- Future Conditions 1% Annual Chance Flood Hazard Zone X
- Area with Reduced Flood Risk due to Levee, See Notes, Zone X
- Area with Flood Risk due to Levee Zone D

**SPECIAL FLOOD HAZARD AREAS**

- Without Base Flood Elevation (BFE) Zone A, V, ADP
- With BFE or Depth Regulatory Floodway Zone AE, AD, AH, VE, AR

**OTHER AREAS OF FLOOD HAZARD**

- 0.2% Annual Chance Flood Hazard, Areas of 1% annual chance flood with average depth less than one foot or with drainage areas of less than one square mile Zone X
- Future Conditions 1% Annual Chance Flood Hazard Zone X
- Area with Reduced Flood Risk due to Levee, See Notes, Zone X
- Area with Flood Risk due to Levee Zone D

**OTHER FEATURES**

- Cross Sections with 1% Annual Chance Water Surface Elevation
- Coastal Transect
- Base Flood Elevation Line (BFE)
- Limit of Study
- Jurisdiction Boundary
- Coastal Transect Baseline
- Profile Baseline
- Hydrographic Feature

**GENERAL STRUCTURES**

- Channel, Culvert, or Storm Sewer
- Levee, Dike, or Floodwall

Map navigation controls: zoom in (+), zoom out (-), and a menu icon (☰).

# WHKS & CO.

ENGINEERS PLANNERS LAND SURVEYORS

FOUAD K. DAOUD, P.E. & S.E., PRESIDENT & CEO  
PENNY L. SCHMITZ, EXEC. VICE PRES., COO & CFO  
RICK G. ENGSTROM, C.E.T., VICE PRESIDENT  
MICHAEL A. ZELINSKAS, P.E., VICE PRESIDENT  
GERALD M. WEILAND, P.E., CHAIRMAN OF THE BOARD

2905 SO. BROADWAY  
ROCHESTER, MN 55904-5515  
phone 507-288-3923  
fax 507-288-2675  
e-mail rochester@whks.com  
website: www.whks.com

September 19, 2005

owner  
copies

Camille Reber, City Clerk  
City of Mantorville  
P. O. Box 188  
Mantorville, MN 55955

RE: Balcome/Smith Easement

Dear Cami:

We recommend that the City of Mantorville vacate the existing 30 foot easement on old Madison Street between 6<sup>th</sup> Street and 7<sup>th</sup> Street on the Balcome/Smith property. We are making this recommendation to accommodate the garage on the existing easement so that the owners do not have to move the garage. The City must than obtain a utility easement from Balcome/Smith over the West 31 feet of old Madison Street between 6<sup>th</sup> Street and 7<sup>th</sup> Street. This recommendation essentially moves the easement from the center of old Madison Street to the west side of old Madison Street. This will allow for the construction of the Northwest Sewer and Water Improvements project per the approved project plans.

Please contact me with any questions.

Sincerely,

WHKS & CO.



William K. Angerman, P.E.

cc: Lee Bjorndal

S:/Jobs/Mantorville/5978.07/Correspondence/City-L2.doc

OTHER OFFICES:

P.O. BOX 1467  
470 CENTRAL AVENUE  
1421 S. BELL AVE. SUITE 103  
167 SINSINAWA AVENUE

MASON CITY, IA 50402-1467  
DUBUQUE, IA 52001-7024  
AMES, IA 50010  
EAST DUBUQUE, IL 61025-1218

PHONE 641-423-8271  
PHONE 563-582-5481  
PHONE 515-663-9997  
PHONE 815-747-8833

RESOLUTION 12-2005

A RESOLUTION AUTHORIZING THE VACATION OF AN EASEMENT

WHEREAS, the City of Mantorville has a 30' utility easement located at Madison Street adjacent to lots 1,2,3,4,5, Block 24 and lots 6,7,8,9,10, Block 21, between Sixth Street and Seventh Street in Frank Mantor's Addition, Mantorville Minnesota.

WHEREAS, the City Council has authorized City Attorney, Lee Bjorndal, to begin the process of vacating the said 30' utility easement.

WHEREAS, the City is requesting a permanent utility easement located at the West 31' of the now vacated Madison Street lying between Block 21 and Block 24 of Frank Mantor's Addition to the City Mantorville, Dodge County, Minnesota; subject to easements and restrictions of record.

WHEREAS, this new easement includes the right for the City of Mantorville and anyone or company acting on its behalf to access the easement area for the purposes of installation and maintenance and repair of the utilities to be located therein and the vacation is subject to the adjacent landowners agreeing to execute the new, proposed easement in order for the other easement to be vacated.

NOW THEREFORE BE IT RESOLVED BY THE CITY COUNCIL OF THE CITY OF MANTORVILLE;

The City Council, at a Special Meeting on Monday, September 19, 2005, has authorized the City Attorney, Lee Bjorndal, to begin the vacation process of the current utility easement retained by the City of Mantorville as described above.

Passed and adopted this 19<sup>th</sup> day of September 2005.

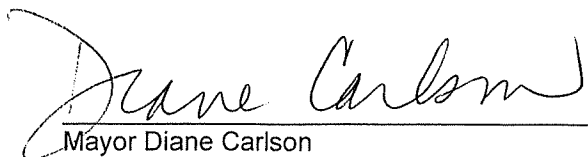
  
\_\_\_\_\_  
Mayor Diane Carlson

  
\_\_\_\_\_  
Attest: City Clerk Camille Reber

**CITY OF MANTORVILLE  
DODGE COUNTY, MINNESOTA**

**RESOLUTION 2026-10**

**A RESOLUTION APPROVING A LOT SPLIT FOR CERTAIN REAL PROPERTY  
LOCATED IN MANTORVILLE, DODGE COUNTY, MINNESOTA**

**WHEREAS**, Richard A. Balcome (the “Applicant”) is fee owner of that certain real property located in Mantorville, Minnesota and legally described on Exhibit A attached hereto (the “Property”); and

**WHEREAS**, the Property is located in the Single-Family (R-1) Zoning District; and

**WHEREAS**, the Applicant has requested to split the Property into two separate parcels; and

**WHEREAS**, Section 151 of the Mantorville Zoning Code titled Subdivision Regulations allows said split to occur; and

**WHEREAS**, the Applicant has submitted a certified survey, attached hereto as Exhibit B, which depicts the requested lot split and proposes two new legal descriptions for the Property as provided on Exhibit C (herein, “Parcel A”) and Exhibit D (herein, “Parcel B”) attached hereto; and

**WHEREAS**, the City Council reviewed the Applicant’s request at its regular meeting on March 9, 2026 during which the City Council confirmed that said lot split and the creation of Parcel A and Parcel B meets all requirements of the City’s subdivision and zoning regulations and there is no involvement of any public utility or street easements.

**NOW, THEREFORE, BE IT RESOLVED**, that the City Council hereby approves the Applicant’s lot split application. The City Clerk-Treasurer is hereby authorized and directed to take any action deemed necessary or convenient in order to effectuate said lot split with the Office of the County Recorder, Dodge County, Minnesota.

Adopted by the Mantorville City Council this 9<sup>th</sup> day of March, 2026.

---

Jeffrey Ingalls, Mayor

---

Gretchen Lohrbach, City Clerk-Treasurer

## EXHIBIT A

### Legal Description of the Property

Lots 7, 8, 9, and 10, Block 21, All in Frank Mantor's Addition to the Village. now City of Mantorville and that part of vacated Madison Street in Frank Mantor's Addition to the City of Mantorville, Dodge County, Minnesota described as follows:

Beginning at the Northeast corner of Lot 5, in said Block 24; thence South to the Southeast corner of Lot 1, in said Block 24; thence East to the Southwest corner of Lot 10 in Block 21; thence North to the Northwest corner of Lot 6 in said Block 21; thence West to the Northeast corner of said Lot 5 in Block 24 the point of beginning.

together with all hereditaments and appurtenances belonging thereto. subject to the following exceptions:

Subject to covenants, easements and restrictions of record.

# EXHIBIT B

## Survey

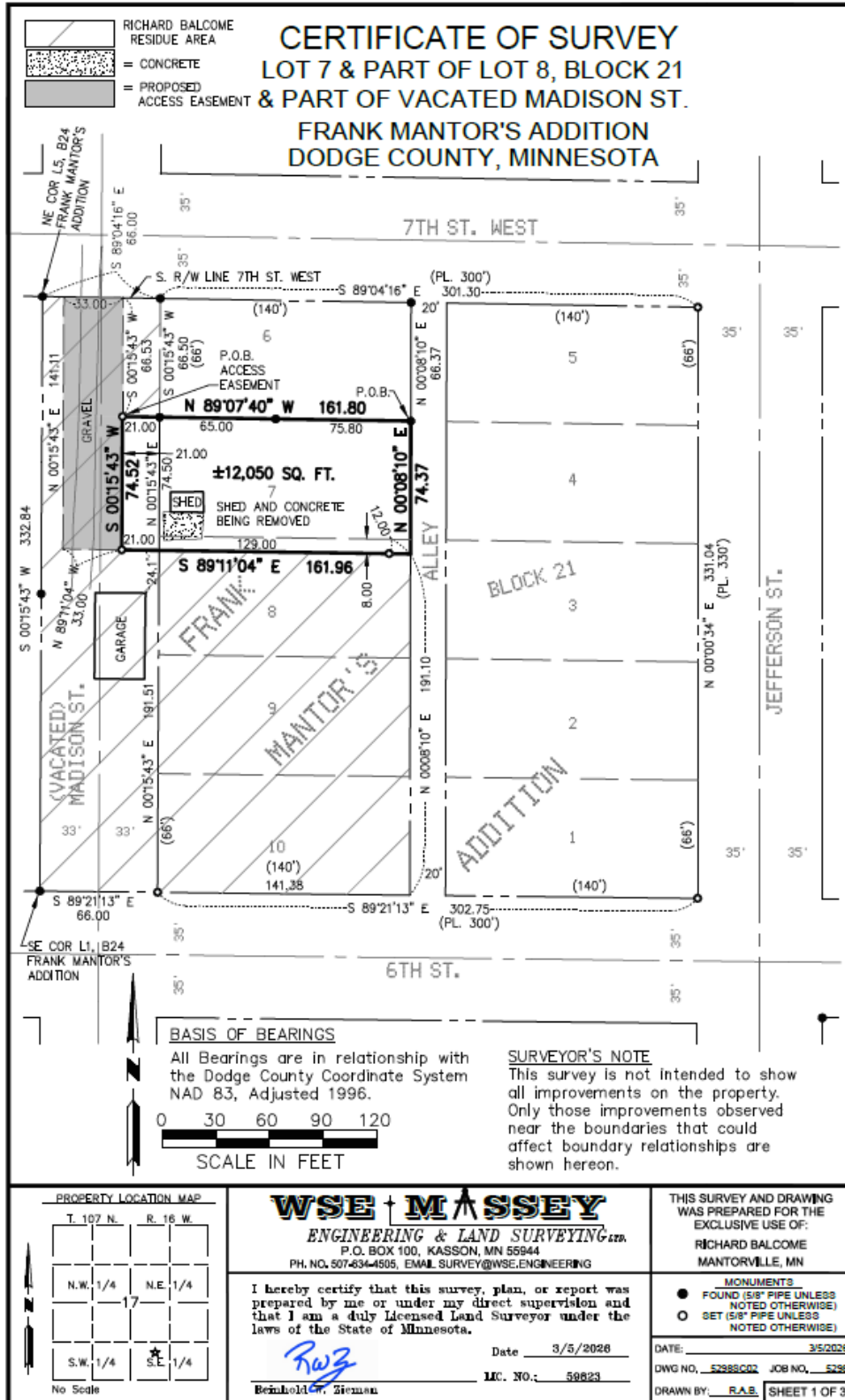

## EXHIBIT C

### Legal Description of "Parcel A"

Lot 7 and that part of Lot 8, Block 21 and that part of vacated Madison Street, FRANK MANTOR'S ADDITION described as follows:

BEGINNING at the northeast corner of Lot 7 of said Block 21; thence North 89 degrees 07 minutes 40 seconds West (NOTE: All bearings are in relationship with the Dodge County Coordinate System NAD '86, Adjusted 1996), along the north line and the westerly extension of said Lot 7, a distance of 161.80 feet; thence South 00 degrees 15 minutes 43 seconds West, 74.52 feet to the westerly extension of the south line of the North 8.00 feet of Lot 8; thence South 89 degrees 11 minutes 04 seconds East, along the westerly extension and the south line of the North 8 feet of Lot 8, a distance of 161.96 feet to the east line of said Lot 8; thence North 00 degrees 08 minutes 10 seconds East, along the east line of said Lot 8 and Lot 7, a distance of 74.37 feet to the northeast corner of said Lot 7 and the POINT OF BEGINNING.

TOGETHER WITH:

An access easement, over and across that part of vacated Madison Street as platted in FRANK MANTOR'S ADDITION lying west of Block 21, described as follows:

Commencing at the northeast corner of Lot 7 of said Block 21; thence North 89 degrees 07 minutes 40 seconds West (NOTE: All bearings are in relationship with the Dodge County Coordinate System NAD '86, Adjusted 1996), along the north line and the westerly extension of said Lot 7, a distance of 161.80 feet to the POINT OF BEGINNING of said access easement; thence South 00 degrees 15 minutes 43 seconds West, 74.52 feet to the westerly extension of the south line of the North 8.00 feet of Lot 8; thence North 89 degrees 11 minutes 04 seconds West, along said westerly extension, 33.00 feet; thence North 00 degrees 15 minutes 43 seconds East, parallel with the west line of said Block 21, a distance of 141.11 feet to the south line of 7th Street West; thence South 89 degrees 04 minutes 16 seconds East, along said south line of 7th Street West, 33.00 feet; thence South 00 degrees 15 minutes 43 seconds East, along the west line of said Block 21, a distance of 66.53 to the POINT OF BEGINNING.

## **EXHIBIT D**

### **Legal Description of "Parcel B"**

Lots 7, 8, 9, and 10, Block 21, All in Frank Mantor's Addition to the Village. now City of Mantorville and that part of vacated Madison Street in Frank Mantor's Addition to the City of Mantorville, Dodge County, Minnesota described as follows:

Beginning at the Northeast corner of Lot 5, in said Block 24; thence South to the Southeast corner of Lot 1, in said Block 24; thence East to the Southwest corner of Lot 10 in Block 21; thence North to the Northwest corner of Lot 6 in said Block 21; thence West to the Northeast corner of said Lot 5 in Block 24 the point of beginning.

together with all hereditaments and appurtenances belonging thereto. subject to the following exceptions:

Subject to covenants, easements and restrictions of record.

EXCEPT:

Lot 7 and that part of Lot 8, Block 21 and that part of vacated Madison Street, FRANK MANTOR'S ADDITION described as follows:

BEGINNING at the northeast corner of Lot 7 of said Block 21; thence North 89 degrees 07 minutes 40 seconds West (NOTE: All bearings are in relationship with the Dodge County Coordinate System NAD '86, Adjusted 1996), along the north line and the westerly extension of said Lot 7, a distance of 161.80 feet; thence South 00 degrees 15 minutes 43 seconds West, 74.52 feet to the westerly extension of the south line of the North 8.00 feet of Lot 8; thence South 89 degrees 11 minutes 04 seconds East, along the westerly extension and the south line of the North 8 feet of Lot 8, a distance of 161.96 feet to the east line of said Lot 8; thence North 00 degrees 08 minutes 10 seconds East, along the east line of said Lot 8 and Lot 7, a distance of 74.37 feet to the northeast corner of said Lot 7 and the POINT OF BEGINNING.

## Building Inspections Services Agreement

THIS AGREEMENT is made and entered into this 22 day of Jan, 2024 by and between Construction Management Services of Rochester, a Division of WSE Engineering Services, Ltd, hereinafter referred to as ("CMS"), and the Jurisdiction of the City of Mantorville, hereinafter referred to as ("the Jurisdiction"), and collectively the Parties.

WHEREAS, the Jurisdiction is desirous of contracting with CMS for the performance of the hereinafter described Building Official functions within its boundaries; and

WHEREAS, CMS is agreeable and desirous of rendering such building inspection services on the terms and the conditions hereinafter set forth.

WHEREAS, CMS and the Jurisdiction mutually agree that the Minnesota Building Code and all corresponding laws, rules and regulations govern this Agreement.

### ARTICLE I

#### Inspection Services

CMS agrees to provide building inspection services within the boundaries of the Jurisdiction to the extent and in the manner hereinafter set forth.

1. Except as otherwise specifically set forth herein, such building inspection services shall only encompass duties and functions of the type coming within the jurisdiction of and customarily rendered by a Building Official under law. Services shall not include those services that are normally provided by the State of Minnesota such as issuance of electrical permits and electrical inspections or any miscellaneous Jurisdiction Ordinances.
2. The Jurisdiction shall, adopt, or not rescind, the latest Minnesota Building Code.
3. CMS will add language similar to the following in their building permit application. The Jurisdiction shall ensure there is no conflict in their code or ordinance with the following.
  - a. *The term "completed" shall include all work proposed in the approved permit. All building permits issued shall complete construction of the project within one hundred and eighty (180) days after the permit is issued, without additional approval. If at the time of application, the project is anticipated to not be completed within one hundred and eighty (180) days, the applicant shall provide the project's anticipated timeline. CMS may adjust for reasonableness and approve project timelines as part of the permit review process up to five hundred and forty (540) days. Projects anticipated to exceed five hundred and forty (540) days shall seek approval from the Jurisdiction's applicable governing body.*
  - b. *A permit holder may request extensions in increments of one hundred and eighty (180) days. CMS may approve up to two extensions if CMS judges steady and continuous progress is being made. Permit holders requesting more than two extensions shall make an application for a new permit. The new permit application shall state the reason and demonstrate that circumstances were beyond the control of the permit holder.*

4. Under this agreement, the Jurisdiction will receive all applications for the applicable building Permit within the Jurisdiction as required by existing laws, codes and ordinances, and shall forward, or cause to be forwarded, to CMS, who shall examine all such applications which are under Jurisdiction to determine compliance with existing Building Codes.
  - a. CMS offers a web-based software to manage Permit Applications. Fees for this service are listed in Appendix A; and the Jurisdiction may opt out of this service with 60-day notice.
5. CMS shall perform their services in accordance with the generally accepted building inspector practices and principles. The standard of performance, the method of providing building inspection services and other matters incident to the performance of the services under this Agreement shall be determined by CMS.
6. Issuance of Permits is broken into two Permit Types:
  - a. Over-The-Counter Permits (Flat Fee Permits). Over-The-Counter Permits are of the nature that do not require a plan review and only require inspection(s). Over-The-Counter permits are valid the moment the fee is paid.
  - b. Plan Reviewed Permits (Valued Permits). Plan Reviewed Permits are of the nature that require plans and various support documents.
7. CMS shall provide job-site inspections of projects under permits as required by existing laws, codes and ordinances, as well as ensure all such special inspections are performed as deemed necessary in order to ensure compliance with existing laws, and upon completion of each project,
8. CMS may contract with other entities for services as building official, provided such other services do not impair or delay the performance of CMS services provided under this Agreement.
9. CMS will provide plan checking services as necessary in all instances where such plan checking is mandatory by existing Federal or State laws, codes or ordinances.
  - a. CMS will provide a cursory review of all "Plan Reviewed Permit" applications to check for compliance to Jurisdiction codes or ordinances; however, a comprehensive review of Jurisdiction codes or ordinances is beyond the scope of this Agreement. CMS will provide written comments for any found deviations to the Jurisdiction Administrator and work closely with applicable planning and zoning staff prior to issuing a permit. No Permit will be issued that knowingly requires a variance to existing Jurisdiction code or ordinance.
10. The Jurisdiction acknowledges that under certain conditions CMS may, or may not, grant a "Limited Notice to Proceed" for certain elements of work depending on project circumstances and completeness of application. Depending on the circumstances and completeness of the application CMS may require the applicant to sign a notarized affidavit that includes acknowledging risk and responsibility for remedy due to work proceeding prior issuance of Permit.

3/9

CMS

### Construction Management Services

717 3rd Ave SE STE 101  
Rochester, MN 55904  
507-282-8206  
www.wse.engineering

### Invoice



A Division of WSE Engineering Services, Ltd

E 101 - 42400 - 300

BILL TO
CITY OF MANTORVILLE PO BOX 188 MANTORVILLE MN 55955

INVOICE#	DATE	TOTAL DUE	DUE DATE	TERMS	ENCLOSED
817-265285-1	2/18/2026	\$ 225.00	3/20/2026	30 Days	

<b>JURISDICTION NAME</b> CITY OF MANTORVILLE	<b>BILLING PERIOD</b> JANUARY 2026	<b>MAKE CHECK PAYABLE TO</b> CONSTRUCTION MANAGEMENT SERVICES
---	---------------------------------------	--

TASK NAME	AMOUNT
CMS Fees	\$ 50.00
Code Consultant Fee	\$ 25.00
iWorQ Retainer Fee	\$ 150.00
Legacy Permit Fees (includes mileage)	\$ -
<b>Subtotal:</b>	<b>\$ 225.00</b>

**BALANCE DUE: \$ 225.00**

Please see attached sheet(s) for an itemized list of charges.

Thank you for your business!



**S.L. CONTRACTING, INC.**

*We Dig for Our Business!*



DBA: ROCHESTER SERVICE CO.

ROCHESTER, MN

**S.L. Contracting, Inc.**

DBA: Rochester Service Company  
2510 Schuster Lane NW  
Rochester, MN 55901  
507-281-5333

# Estimate

Date: 3/2/2026  
Estimate #: 3168

City of Mantorville  
PO Box 188  
Mantorville, MN 55955

Description	Qty	Rate	Total
2026 SPRING SWEEPING			
Spring Street Sweeping [HRS]	8	250.00	2,000.00
We hereby propose to furnish labor and material - complete with above specifications, for the sum listed above, with NET30 payment to be made as work is completed. Sweeping to be billed by the hour.		0.00	0.00
<b>Sales Tax (6.875%)</b>			\$0.00
<b>Total</b>			\$2,000.00

Notice to Proceed \_\_\_\_\_

**Durst Outdoor Services**

5135 Lehman Ln NW  
Rochester, MN 55901 US  
+15072084020  
office@durstoutdoorservices.com



**Estimate**

ADDRESS  
City Of Mantorville Township  
25582 590th ST  
Attn: Carol  
Mantorville, MN 55955

ESTIMATE 4025  
DATE 03/03/2026

DESCRIPTION	QTY	RATE	AMOUNT
2026 Sweeping of Town	1	3,345.00	3,345.00
SUBTOTAL			3,345.00
TAX			0.00
TOTAL			<b>\$3,345.00</b>

Accepted By

Accepted Date

## Important Information Regarding Property Assessments

**This may affect your 2027 property tax payments.**

The Board of Appeal and Equalization of the City of Mantorville will meet:

Date/Time: April 20, 2026 at 5:30 pm

Location: City Hall

The purpose of this meeting is to determine whether taxable property in the jurisdiction has been properly valued and classified by the assessor.

If you believe the value or classification of your property is incorrect, please contact your assessor's office to discuss your concerns. If you disagree with the valuation or classification after discussing it with your assessor, you may appear before the local board of appeal and equalization. The board will review your assessments and may make corrections as needed. Generally, you must appeal to the local board before appealing to the county board of appeal and equalization.

Given under my hand this 6<sup>th</sup> day of March, 2026

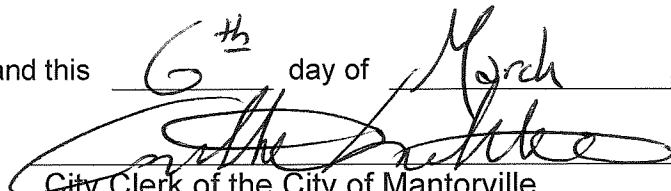
  
\_\_\_\_\_  
City Clerk of the City of Mantorville



2026-09 RESOLUTION OF APPLICATION

BE IT RESOLVED that the City of Mantorville is hereby applying to the Minnesota Public Facilities Authority for a loan and/or grant from the Drinking Water Revolving Fund for a lead service line replacement project as described in the application.

BE IT FURTHER RESOLVED that the City of Mantorville estimates the MPFA-Financed amount to be \$600,000 or the as-bid cost of the project.

BE IT FURTHER RESOLVED that the City of Mantorville has the legal authority to apply for the loan and/or grant, and the financial, technical, and managerial capacity to repay the loan and ensure proper construction, operation and maintenance of the project for its design life.

I CERTIFY THAT the above resolution was adopted by the City of Mantorville on 3/9/2026 (month, day, and year).

Signed: \_\_\_\_\_  
Name: \_\_\_\_\_  
Title: \_\_\_\_\_

Witnessed: \_\_\_\_\_  
Name: \_\_\_\_\_  
Title: \_\_\_\_\_

# Well #3 Feasibility

Mantorville, MN

I hereby certify that this plan, specification or report was prepared by me or under my direct supervision and that I am a duly Licensed Professional Engineer under the laws of the State of Minnesota.

\_\_\_\_\_  
Bryan J. Kaemingk, P.E.

\_\_\_\_\_  
Date 55492  
License. No.

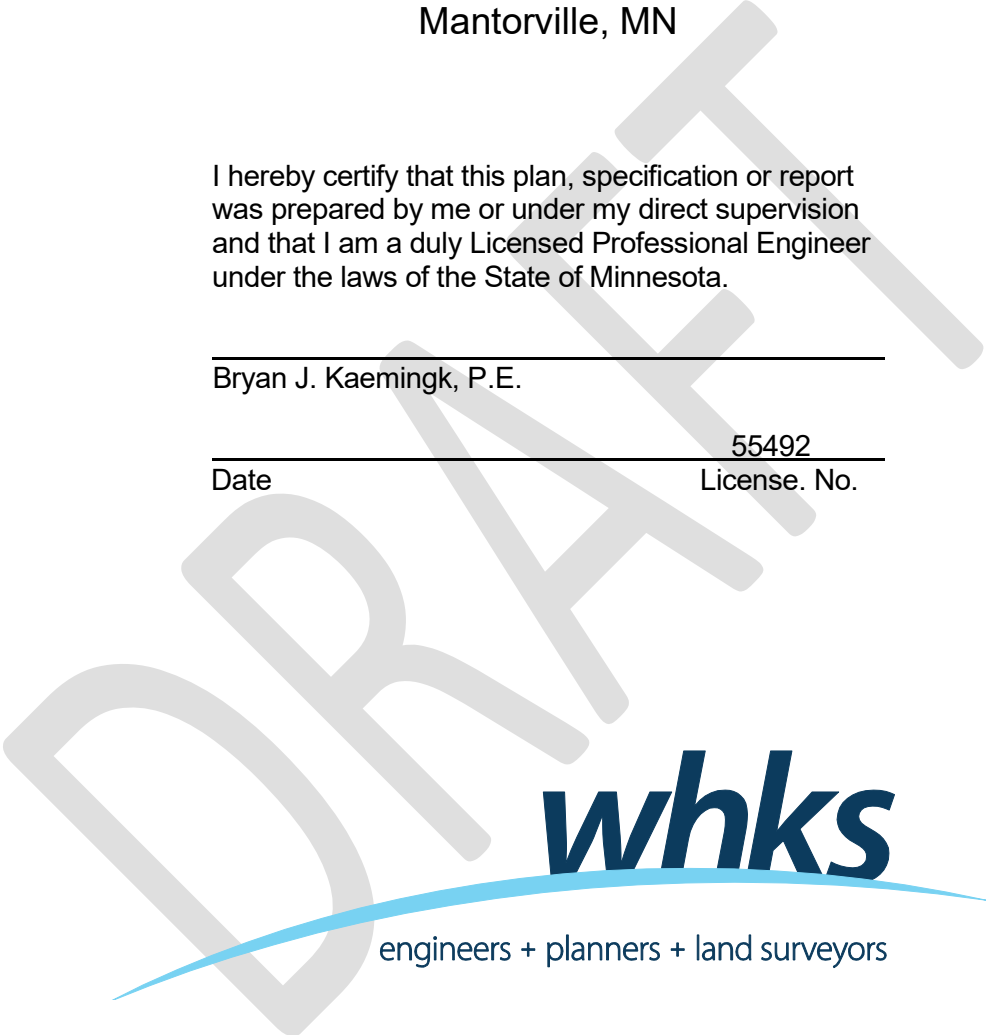

## Introduction

The City of Mantorville has requested an assessment regarding the feasibility of drilling a third well. Currently, Well #2 serves as the primary water source for the city; however, it is approaching the end of its serviceable life. The casing of Well #2 was lined in the 1990s. This lined casing pipe is failing and has large vertical alignment issues. Due to this prior lining and alignment concern, further re-lining is not a viable solution for addressing the failing casing. If the casing pipe fails, the Well will become inoperable. Additionally, the vertical alignment issues create long term issues maintaining the pump and column pipe. The City currently meets Ten State Standards requirements for source capacity with its only emergency backup at Well #1; however, it lacks sufficient capacity to support extended periods of high demand. Furthermore, as identified in the City's 2017 Wellhead Protection Plan, the shallow depth of Well #1 raises concerns about potential vulnerability to contamination; however, contaminant levels have never exceeded regulatory standards.

Mantorville currently has two wells in operation. Well #1, built in 1952, draws from the St. Peter aquifer and can supply up to 125 gallons per minute. This well features an 8-inch diameter casing and reaches a depth of 155 feet; it serves as an emergency backup and is located south of City Hall. Well #2, constructed in 1970, utilizes the Jordan aquifer and originally had a 10-inch diameter casing. Following a lining installation, its casing diameter is now 6 inches, and the well extends to 670 feet deep. It has a capacity of 425 gallons per minute.

As requested by the City, this report examines two locations for the new Well #3, the existing Well #2 location and the water tower location. Additionally, four more locations are presented as options and should be considered by the City as potential well locations.

See figure below for water tower and well locations. A more detailed map is attached to this report.



City of Mantorville, Well and Tower locations.

## Recommendation

---

After evaluating the two primary sites requested by the City for consideration, it is recommended that Well #3 be constructed at the water tower site. However, the City should also review the four additional locations outlined in this report for further consideration. The final design for Well #3 should be completed during the winter of 2026/27, with construction anticipated to take place from 2027 to 2028. Well #2 should continue to be maintained and used as a backup; it should be operated weekly to ensure that equipment remains functional and the well stays disinfected. Additionally, Well #1 should be maintained and kept available as an additional emergency backup source.

There are various funding sources available to support the recommended project activities. Loans are more likely the only funding option for this project, since grants for this type of work are limited. The City is encouraged to explore these opportunities.

## Cost Opinions

---

Preliminary opinions of probable construction cost have been prepared for the improvements discussed and recommended in this report. Costs do not include financing or legal fees. The opinions of cost have been prepared to reflect anticipated costs during the 2026 construction season for projects let by competitive bidding, unless noted otherwise. No attempt has been made to forecast any price increases or decreases. The opinions of probable cost are presented for planning purposes only and are not a guarantee of the final project cost.

Future cost estimates should be adjusted to reflect cost changes from the time of this report. At the completion of design, a revised opinion of probable construction cost should be prepared for evaluation of the bids to be received. It is recommended that the City plan to update projected costs on an annual basis to account for changes in the bidding climate as well as fast-paced cost increases for materials and labor currently being experienced within the construction industry.

## Location Discussion

---

Each location discussed below has different benefits and issues. However, the proposed equipment, well, and building would be the same at each location with only slight variations with sitework and piping. The information presented below is preliminary and may change during final design.

The proposed building would be 11-feet by 30-feet premanufactured building, which contains separate chemical rooms for fluoride, polyphosphate and chlorine. Although the City currently uses chlorine gas as their disinfection, sodium hypochlorite should be considered for the new building. Chlorine gas leaks can cause health concerns and property damage as the City previously experienced in Well #2. Sodium hypochlorite minimizes these health and property damage risks. Additionally, the well building would contain electrical equipment and associated process piping. The proposed well would be a 12-inch internal diameter with an 18-inch outside diameter casing with grout in the annular space. The dual casing construction allows for longevity while the size allows for continued maintenance for the life of the well. After reviewing the pump records and projected population growth at an assumed rate of 1.5%, it is proposed to match the size and type of the existing pump currently installed at Well #2. The proposed pump would be a vertical turbine pump at approximately 425 gpm capacity with a 50 horsepower motor. The pump type (vertical turbine vs. submersible) and size would be further evaluated during final design.

The Well Head Protection Plan will need to be updated to reflect the proposed Well #3 location.

## Alternative 1 - Existing Well #2 Location

This location would include installing a building and well northwest of the Well #2 as shown in the figure below. A more detailed map of this location is attached to this report.

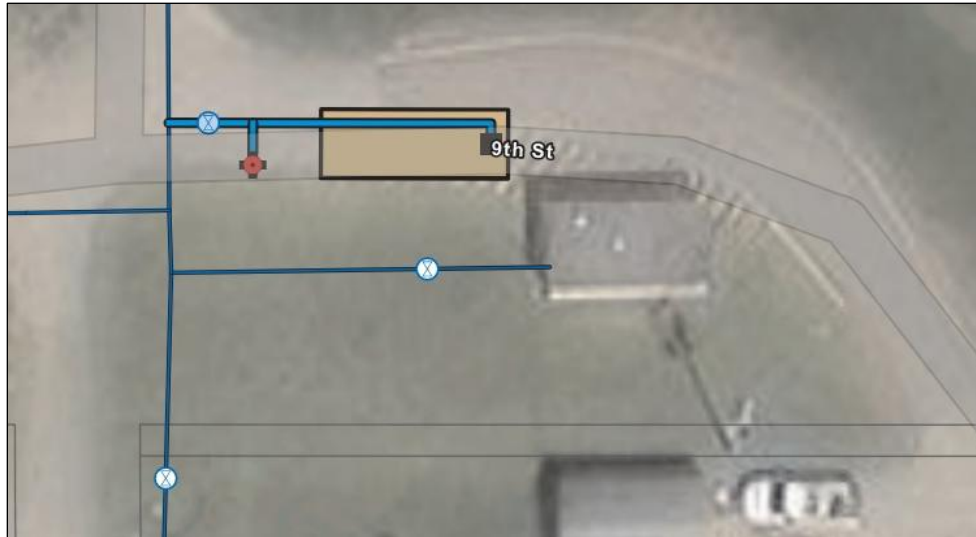

Alternative 1 – Existing Well #2 Location

There are several issues to be considered with this location. The current Well #2 and the proposed site are located within the City right-of-way, resulting in additional costs to abandon part of 9th Street for regulatory purposes. Due to required regulatory isolation distances, the proposed well sits in the middle of 9th Street, primarily because of the setback requirements from the southern property line. On the north side, setback requirements require a roughly 125-foot by 25-foot easement (see attached map for details). Placing a new well at this location does not fully resolve redundancy concerns, as both wells would share power, water connections, and remain vulnerable to the same natural hazards. However, this location is not expected to introduce unforeseen system issues since the water source and connection are similar to the existing Well #2, and it avoids potential taste and odor problems associated with the water tower site.

Cost Opinion   Alternative 1 - Existing Well #2 Location				
Item	Qty	Unit	Unit Cost	Total Cost
Mobilization @ 5%	1	LS	\$80,000	\$80,000
Site Work	1	LS	\$100,000	\$100,000
Easement for Isolation Requirements	1	LS	\$10,000	\$10,000
Connect to Ex. Watermain	1	LS	\$25,000	\$25,000
New Well & Pump	1	LS	\$900,000	\$900,000
Motor Control Center	1	LS	\$40,000	\$40,000
Wellhouse	1	LS	\$300,000	\$300,000
Controls	1	LS	\$50,000	\$50,000
Chemical Feed Equipment	1	LS	\$30,000	\$30,000
Subtotal				\$1,525,000
Contingencies @ 10%				\$150,000
Engineering @ 15%				\$230,000
<b>Total</b>				<b>\$1,915,000</b>

## Alternative 2 - Water Tower Location

This location would include installing the building and well west of the current water tower as shown in the figure below. A more detailed map of this location is attached to this report.

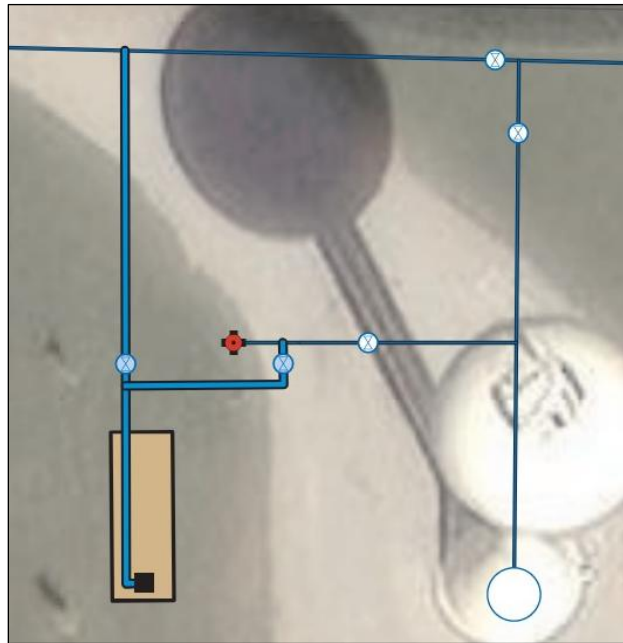

Alternative 2 – Water Tower Location

There are several items to consider as part of this option. Locating the water tower and well at a single site may result in water age problems, potentially including taste and odor issues. To mitigate this, a valve can be closed to ensure water from the well is circulated through the system before entering the tower. Adjusting well and tower set points can also improve circulation. Fire flow may be affected by both structures at the same location. As with the Well #2 site, placing major infrastructure together increases vulnerability to events such as storms and power outages. The proposed site provides sufficient area for construction and meets Well isolation requirements, so no additional costs for abandoning right-of-way or easements are expected. This configuration allows Well #2, pending assessment of column via televising, to serve as a true emergency backup, being located separately from the proposed Well #3.

Cost Opinion   Alternative 2 - Water Tower Location				
Item	Qty	Unit	Unit Cost	Total Cost
Mobilization @ 5%	1	LS	\$80,000	\$80,000
Site Work	1	LS	\$25,000	\$25,000
Connect to Ex. Watermain	1	LS	\$25,000	\$25,000
New Well & Pump	1	LS	\$900,000	\$900,000
Motor Control Center	1	LS	\$40,000	\$40,000
Wellhouse	1	LS	\$300,000	\$300,000
Controls	1	LS	\$50,000	\$50,000
Chemical Feed Equipment	1	LS	\$30,000	\$30,000
Subtotal				\$1,450,000
Contingencies @ 10%				\$150,000
Engineering @ 15%				\$220,000
<b>Total</b>				<b>\$1,820,000</b>

## Additional Locations to Consider

Although other locations may have different issues than presented above for Well #2 and water tower locations, it is worth exploring some additional locations. Mainly these locations will separate major infrastructure. These locations should be reviewed by the City for potential Well #3 sites.

According to Dodge County records, there are 21 City owned parcels not including the Well #2 site and Water tower site. Of these 21, there are 16 parcels that are adjacent to the existing water system. Of those 16, it appears there are four (4) locations that have enough open space, are large enough for setbacks, and do not need a large amount of site work or tree clearing for the well. These four (4) locations are shown below, which are Riverside Park, (320 N Main Street), Slingerland Park (209 5<sup>th</sup> Street W), Mantor Field (400 Block 7<sup>th</sup> Street W), and the City Shop (1008 10<sup>th</sup> Street E). The City should discuss these locations as a possible well location. It is expected that the cost of a well at these locations would be approximately the same as Alternative 1 or 2, at \$1.8 to \$1.9 million.

See the figure below for the four (4) locations that the City should consider for a Well location. A more detailed map of this location is attached to this report.

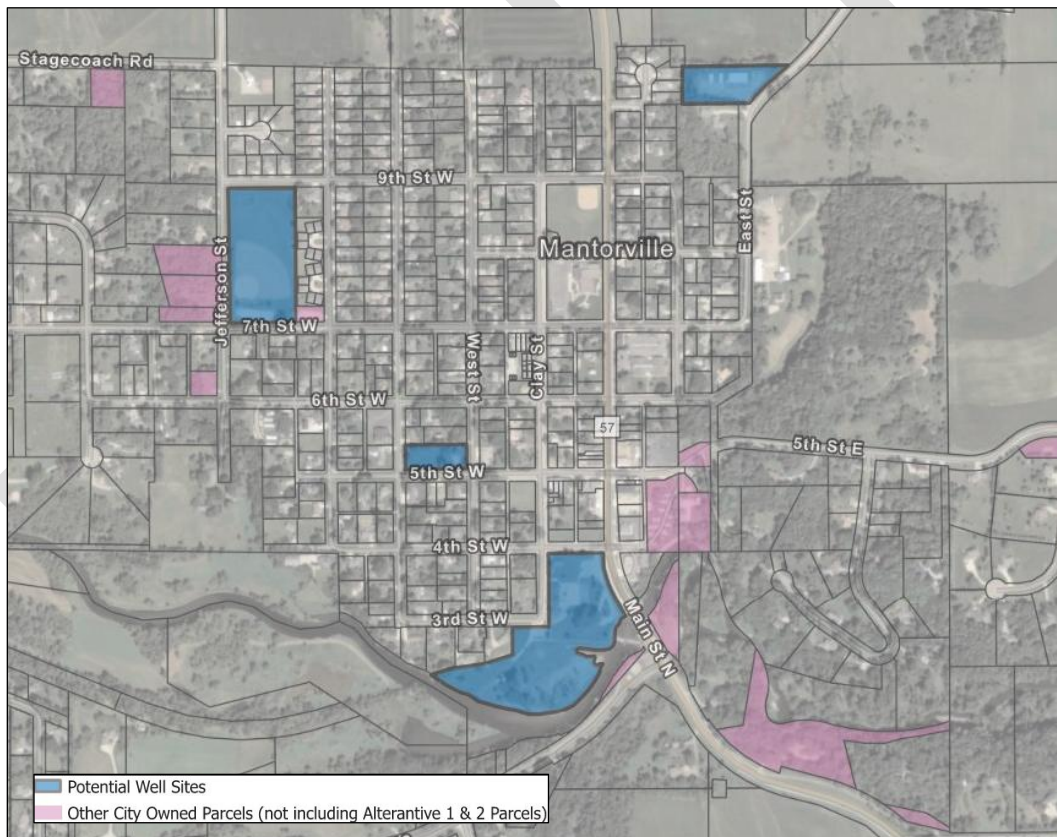

# Water System Mantorville, MN

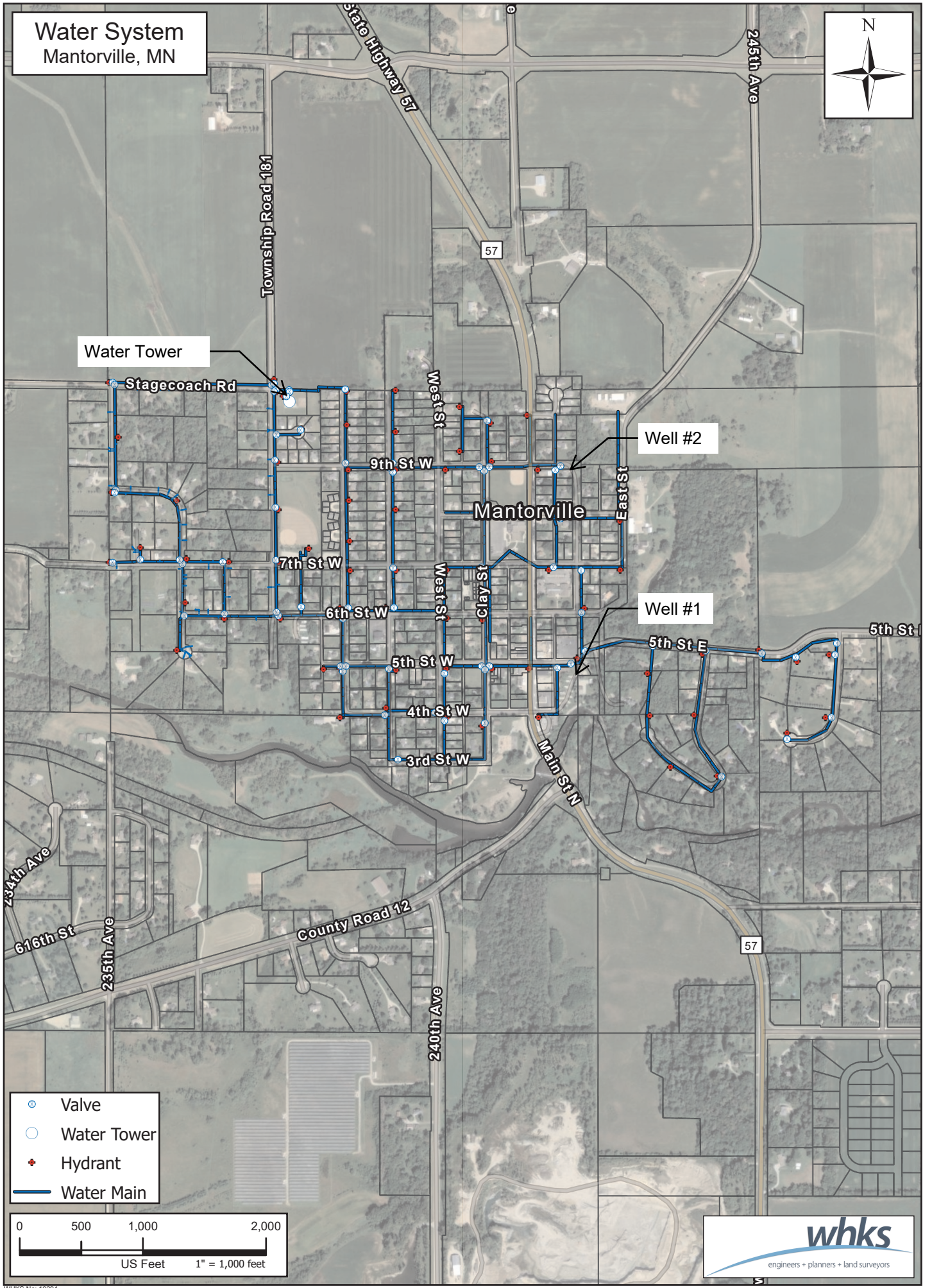

Water Tower

Well #2

Well #1

- ⊙ Valve
- Water Tower
- ♦ Hydrant
- Water Main

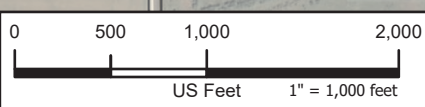

Alternate #1 - Existing Well #2 Location  
Mantorville, MN

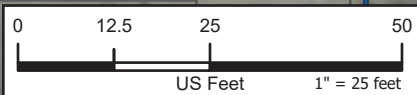
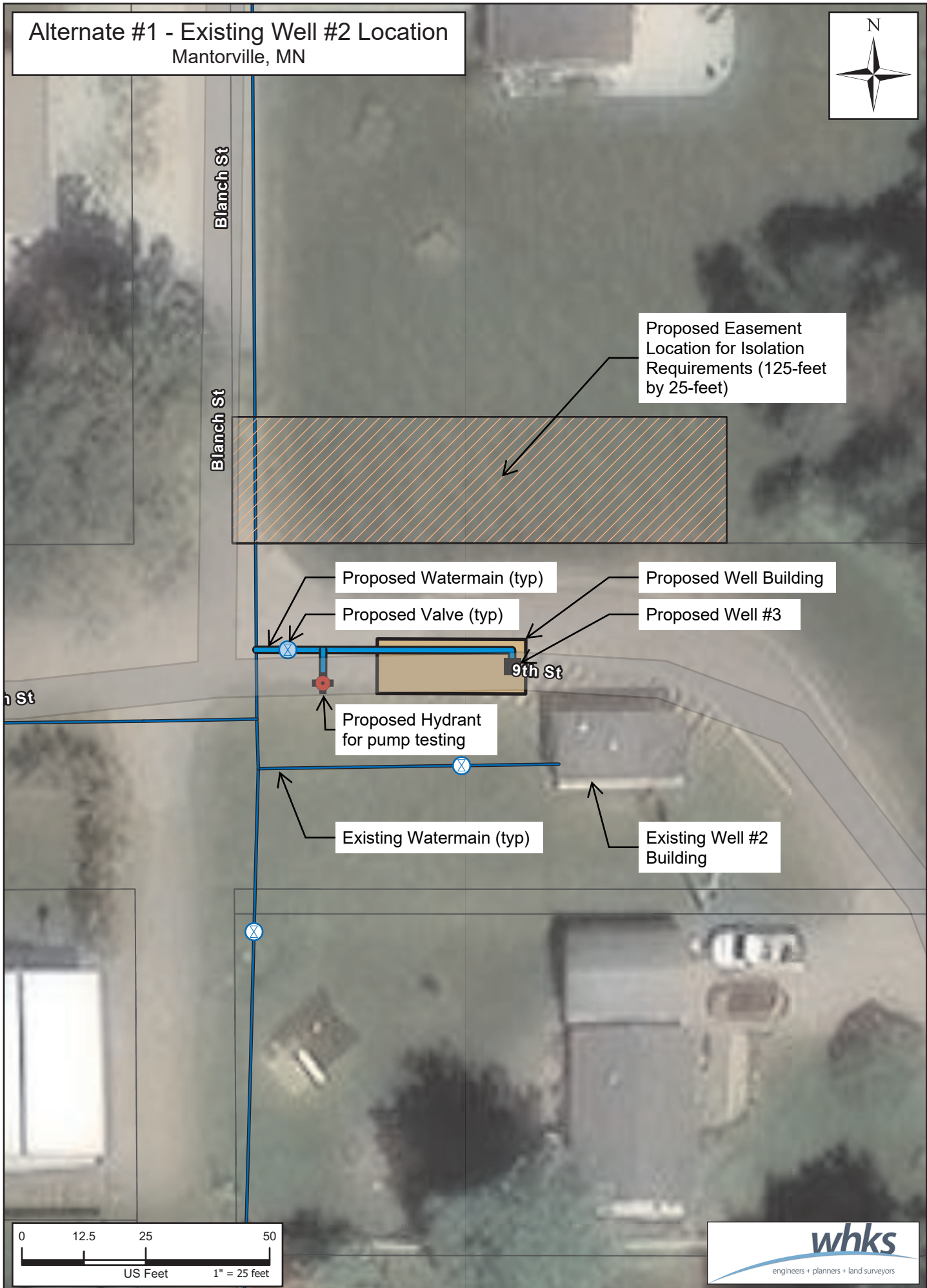

# Alternate #2 - Water Tower Location Mantorville, MN

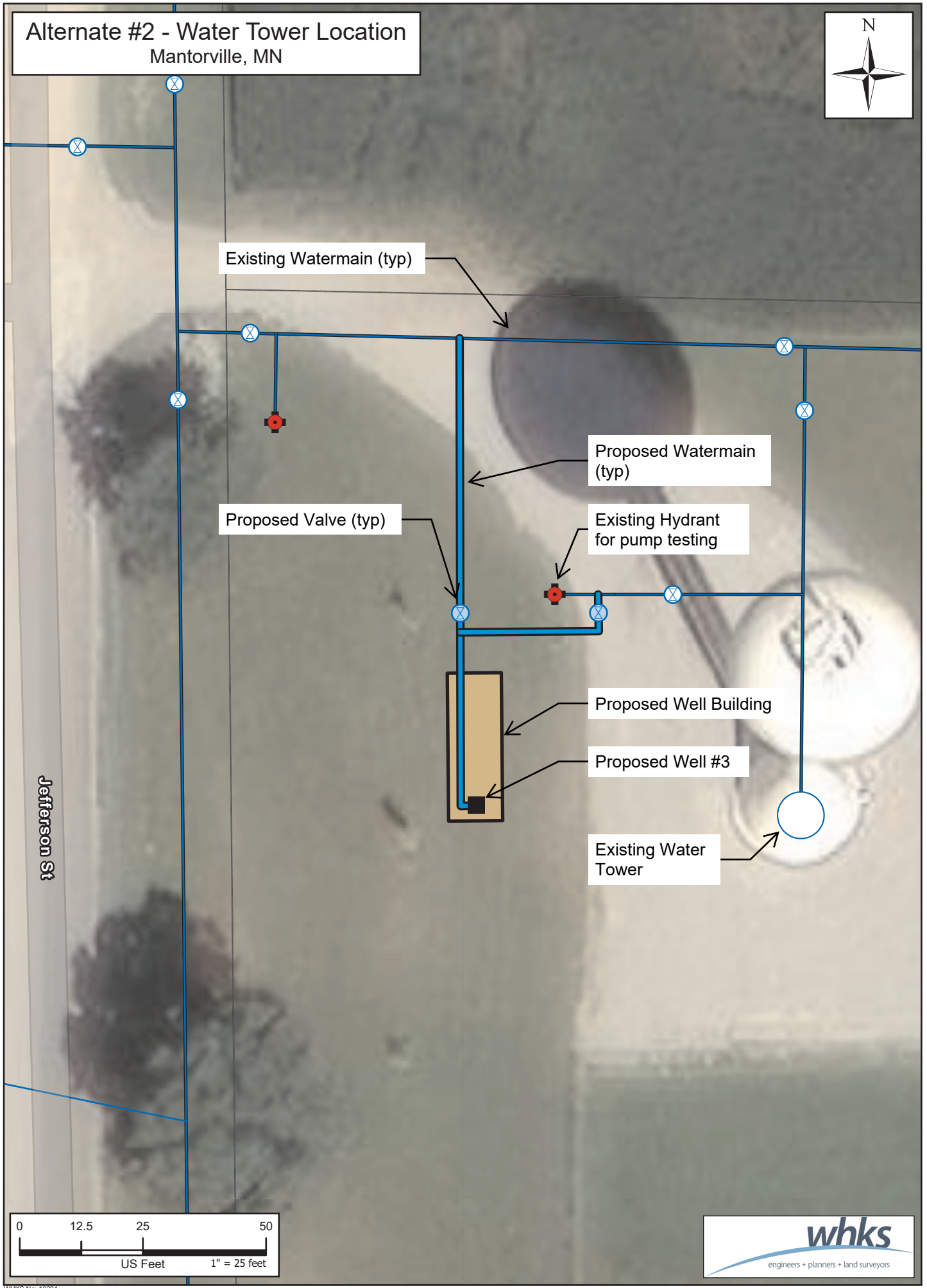

Existing Watermain (typ)

Proposed Watermain (typ)

Proposed Valve (typ)

Existing Hydrant for pump testing

Proposed Well Building

Proposed Well #3

Existing Water Tower

Jefferson St

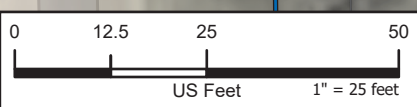

# Additional Locations to Consider Mantorville, MN

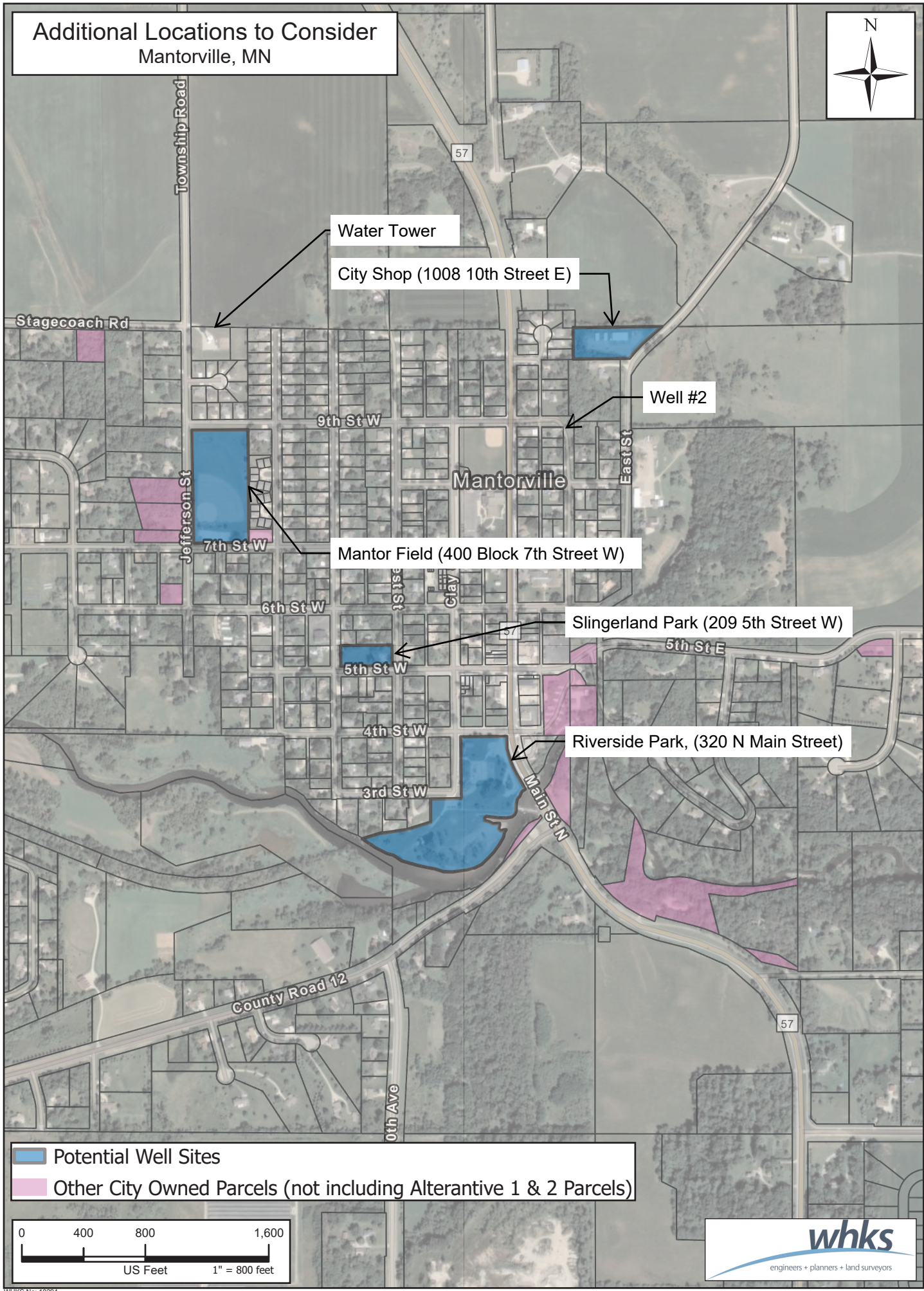

- Potential Well Sites
- Other City Owned Parcels (not including Alterantive 1 & 2 Parcels)

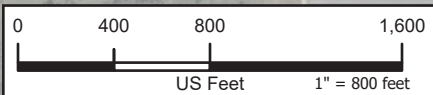



## 2025 City Council Committee Assignments

Member	Annexation	Budget	*Chamber	COG	Deputy Mayor	*EDA	Finance	*Fire Department	Infrastructure	*Joint Powers	*MRA	*Park Board	Personnel	Planning & Zoning	*Township	Waste & Storm Water
Jim Potter	X		B					B			X	X			X	X
Lynette Nash		X			X			X						X	X	
Kim Boyum			X			X				X				X		X
Open Seat																
Jeff Ingalls	X			X			X		X		X				X	

**X** Primary Member  
**B** Backup for Primary  
**X** One space still open

ASSIGNMENT	DETAILS
DEPUTY MAYOR	Fills in for Mayor, as needed
CHAMBER OF COMMERCE	Meets first Wednesday of the month at the Welcome Center - 8:00 am
EDA (ECONOMIC DEVELOPMENT AUTHORITY)	Meets third Monday of the month in Council Chambers - 6:30 pm
FIRE DEPT GENERAL MEETING	Meets the 1st Wednesday of the Month in Fire Hall - Maintenance 6:00 pm; General Meeting 7:30 pm
KM PARK & REC JOINT POWERS BOARD	Meets quarterly
MRA (MANTORVILLE RESTORATION ASSN)	Meets second Tuesday of the month at Greek Revival Building - 7:00 pm
PARK BOARD	Meets last Tuesday of the month in Council Chambers - 6:30 pm Mantorville Township meets the first Monday of each month - 6:30 pm, Mantorville Township Hall Milton Township meets the first Monday of each month - 7:00 pm, Milton Town Hall
TOWNSHIP REPRESENTATIVES	Wasioja Township meets the second Monday of each month - 1:00 pm (Dec-Mar); 7:00 pm (Apr-Nov), Wasioja Town Hall Meets once every quarter - 7:00 am, County Seat Coffeehouse, or as scheduled
COUNCIL OF GOVERNMENTS	
ALL OTHERS	Meets quarterly, no backup (K-M appointed by Superintendent)

# City of Mantorville - 2026 Meeting Calendar

Meeting	Schedule	Meeting	Schedule
City Council	2nd Monday @ 6:30 PM	Mantorville Fire Dept - Officers Meeting	Tuesday Prior to 1st Wed @ 7:00 PM
City Council Work Session & Special Meetings	Held as Needed	Mantorville Fire Dept Equip/Truck Maintenance & General Meeting	1st Wed - 6:00pm Maintenance; 7:30pm Members Meeting
Economic Development Authority	3rd Monday @ 6:30 PM	Decorations Committee	TBD
Parks & Recreations Board - March - November	Last Tuesday @ 6:30 PM	Mantorville Fire Dept - Training	6:30pm - 2nd & 3rd Wednesdays
This Color Represents more than one meeting schedule on the same date - See Schedules listed above			
<b>Other Meetings:</b>			
Chamber of Commerce	1st Wednesday, Greek Revival House 8:00 AM	<b>LBAE (Local Board of Appeal and Equalization) Meets April 20th</b>	
Dodge County Board of Commissioners	2nd Tues @ 8:00 AM and 9:30 AM 4th Tues @ 3:30 PM and 5:00 PM	<b>No Government Meetings May be Held Between 6:00 PM and 8:00 PM</b>	
		<b>Holidays</b>	

**2026 Holidays Observed:**

Date	Day of Week	Holiday Name
January 1, 2025	Thursday	New Years Day
January 19, 2025	Monday	Martin Luther King Jr. Day
February 16, 2025	Monday	Washington's Birthday (Presidents Day)
May 25, 2025	Monday	Memorial Day
June 19, 2025	Friday	Juneteenth
July 3, 2025	Friday	Independence Day
September 7, 2025	Monday	Labor Day
November 11, 2025	Wednesday	Veterans Day
November 26, 2025	Thursday	Thanksgiving
November 27, 2025	Friday	Thanksgiving
December 25, 2025	Friday	Christmas Day

**Mantorville City Council will have one meeting per month for Year 2026**

**Additional Meetings will be held if necessary**

## MARCH

Sun	Mon	Tue	Wed	Thur	Fri	Sat
1	2	3 MFD Officer	4 MFD Maint & General	5	6	7
8	9 City Council	10	11 MFD Training	12	13	14
15	16 EDA	17	18 MFD Training	19	20	21
22	23 Alt. Meeting Day	24	25	26	27	28
29	30	31 Parks & Rec & MFD				

## FEBRUARY

Sun	Mon	Tue	Wed	Thur	Fri	Sat
1	2	3 MFD Officer	4 MFD Maint & General	5	6	7
8	9 City Council	10	11 MFD Training	12	13	14
15	16 Holiday	17	18 MFD Training	19	20	21
22	23 Alt. Meeting Day	24	25	26	27	28

## JANUARY

Sun	Mon	Tue	Wed	Thur	Fri	Sat
				1 New Year's Day	2	3
4	5	6 MFD Officer	MFD Maint & General	8	9	10
11	12 City Council	13	14 MFD Training	15	16	17
18	19 Martin Luther King Jr.	20	21 MFD Training	22	23	24
25	26 Alt. Meeting Day	27	28	29	30	31

## JUNE

Sun	Mon	Tue	Wed	Thur	Fri	Sat
	1	2 MFD Officer	3 MFD Maint & General	4	5	6
7	8 City Council	9	10 MFD Training	11	12	13
14	15 EDA	16	17 MFD Training	18	19 Holiday	20
21	22 Alt. Meeting Day	23	24	25	26	27
28	29	30 Parks & Rec & MFD				

## MAY

Sun	Mon	Tue	Wed	Thur	Fri	Sat
					1	2
3	4	5 MFD Officer	6 MFD Maint & General	7	8	9
10	11 City Council	12	13 MFD Training	14	15	16
17	18 EDA	19	20 MFD Training	21	22	23
24	25 Holiday	26 Parks & Rec	27	28	29	30
31						

## APRIL

Sun	Mon	Tue	Wed	Thur	Fri	Sat
			1 MFD Maint & General	2	3	4
5	6	7	8 MFD Training	9	10	11
12	13 City Council	14	15 MFD Training	16	17	18
19	20 LBAE meeting	21	22	23	24	25
26		28 Parks & Rec	29	30		

## JULY

Sun	Mon	Tue	Wed	Thur	Fri	Sat
			1 MFD Maint & General	2	3 Holiday	4
5	6	7	8 MFD Training	9	10	11
12	13 City Council	14	15 MFD Training	16	17	18
19	20 EDA	21	22	23	24	25
26	27 Alt. Meeting Day	28 Parks & & Rec	29	30	31	

## AUGUST

Sun	Mon	Tue	Wed	Thur	Fri	Sat
						1
2	3	4 MFD Officer	5 MFD Maint & General	6	7	9
9	10 City Council	11 Primary Election	12 MFD Training	13	14	15
16	17 EDA	18	19 MFD Training	20	21	22
23	24 Alt. Meeting Day	25 Parks & Rec	26	27	28	29
30	31					

## SEPTEMBER

Sun	Mon	Tue	Wed	Thur	Fri	Sat
		1 MFD Officer	2 MFD Maint & General	3	4	5
6	7 Labor Day	8	9 MFD Training	10	11	12
13	14 City Council	15	16 MFD Training	17	18	19
20	21 EDA	22	23	24	25	26
27	28 Alt. Meeting Day	29 Parks & & Rec	30			

## OCTOBER

Sun	Mon	Tue	Wed	Thur	Fri	Sat
4	5	6 MFD Officer	7 MFD Maint & General	8	9	10
11	12 City Council	13	14 MFD Training	15	16	17
18	19 EDA	20	21 MFD Training	22	23	24
25	26 Alt. Meeting Day	27 Parks & & Rec	28	29	30	31

## NOVEMBER

Sun	Mon	Tue	Wed	Thur	Fri	Sat
1	2	3 Election Day	4 MFD Maint & General	5	6	7
8	9 City Council	10	11 Holiday	12	13	14
14	16 EDA	17	18 MFD Training	19	20	21
22	23 Alt. Meeting Day	24 Last Park & Rec Meeting	25	26 Thanks Giving	27 Thanks Giving	28
29	30					

## DECEMBER

Sun	Mon	Tue	Wed	Thur	Fri	Sat
		1 MFD Officer	2 MFD Maint & General	3	4	5
6	7	8	9 MFD EMR Training	10	11	12
13	14 City Council	15	16 MFD Training	17	18	19
20	21 EDA	22	23	24	25 Holiday	26
27	28	29	30	31		